



# INDUSTRIAL CASE STUDY

## SCROLL COMPRESSOR ECCENTRIC CRANK PIN SEALS



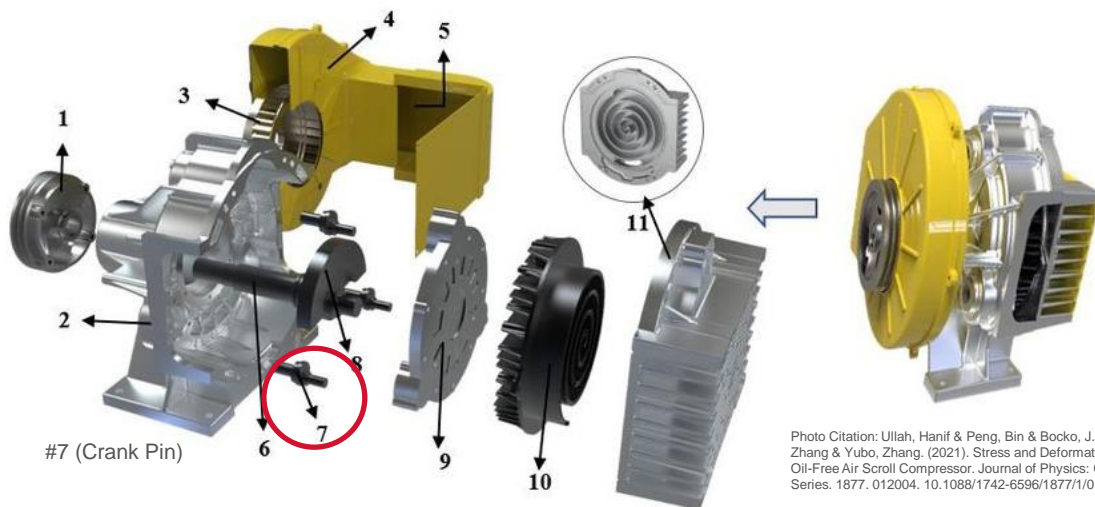

Photo Citation: Ullah, Hanif & Peng, Bin & Bocko, J. & Pengcheng, Zhang & Yubo, Zhang. (2021). Stress and Deformation Analysis of Oil-Free Air Scroll Compressor. Journal of Physics: Conference Series. 1877. 012004. 10.1088/1742-6596/1877/1/012004.

## OMNISEAL® ROTARY LIP SEALS

### SCROLL COMPRESSOR ECCENTRIC CRANK PIN SEALS

Roland Wagner May 2025

INDUSTRIAL LOW WEAR EXTENDED SERVICE COST SAVING

#### Environment

Industrial scroll compressors are widely used for compressing air or refrigerant in heating, ventilation, air conditioning and refrigeration systems. They are known for their high efficiency, reliability, and quieter operation compared to traditional reciprocating compressors. As a type of positive-displacement compressor that works through the internal compression of air or gas, ensuring a tight seal at various dynamic points is critical for optimal performance. One such critical point is the eccentric crank pin where rotary lip seals are often used. The crank pin serves as the pivot for the orbiting scroll, which continuously compresses the media. When the crank pin is eccentric, sealing control around this component becomes more complex and challenging.

#### Challenge

During long-term operational use, compressor manufacturers observed premature lip seal wear. This wear led to decreased system efficiency, shorter service intervals, increased cost, and potential compressor damage. Specifically, the eccentric crank pin was found to be a critical area where leaks occurred due to inadequate sealing.

## Solution

Using our many years of knowledge from collaborating with scroll compressor partners, Omniseal Solutions' engineering and technical teams conducted an extensive review to solve the crank pin sealing problem. The following steps were quickly taken to address the sealing and wear issues:

- **Advanced Material Selection:** The global team explored various lip sealing materials with high performance properties: superior wear resistance, thermal stability, and low friction characteristics. A new type of lip seal material was selected, offering higher flexibility versus traditional lip seal materials.
- **Seal Design Improvements:** A precision seal using a "FEA design, testing, feedback loop approach" was developed to reduce validation costs. The improved seal design increased dry running capabilities as well as optimized lip length and lip load that minimized the risk of leakage due to wear or misalignment.
- **Rigorous Testing & Prototyping:** Multiple prototypes of the new lip sealing system were created with our internal, controlled laboratory conditions. Leak tests were conducted to ensure that the new rotary lip seal provided a tight and durable seal at the crank pin location. Seal longevity was accurately evaluated by running the scroll compressors through durability cycles and real-world field operating conditions.

As a result of this thorough design and testing processes, our custom Omniseal® rotary lip seals solved premature wear, providing a longer-term solution that saves our industrial customer cost and time.

Next-Gen Rotary Lip  
Seals Ensure Peak  
Performance, Longevity  
& Reduced Costs

---



### Benefits

- Lower wear
- Extended service intervals
- Lower seal cost due to simplified design



## Design Expertise & Tailor-made Solutions for Your Critical Applications

Omniseal Solutions is a global engineering leader with over 65 years of historical legacy, relentlessly dedicated to the design and manufacture of precision sealing and wear control solutions that protect critical applications in the most demanding environments and passionately driven to push *Beyond the Boundaries of Possible*.



### Contact Our Expert

#### **Roland Wagner**

District Sales Manager – Industrial  
Northern Europe  
Willich, Germany

+49 177 3869254

[roland.wagner@saint-gobain.com](mailto:roland.wagner@saint-gobain.com)

Omniseal Solutions  
[help@omniseal-solutions.com](mailto:help@omniseal-solutions.com)  
[www.omniseal-solutions.com](http://www.omniseal-solutions.com)