



Omniseal Solutions
SAINT-GOBAIN

OMNISEAL® POLYMERS

SPRING-ENERGIZED SEALS



BEYOND
the boundaries of possible

SAINT-GOBAIN

Welcome to the Omniseal Solutions' World: Experience You Can Rely On ... Time After Time



Saint-Gobain has a rich tradition of excellence that dates back more than 350 years. Today, it is among the world's top 100 industrial corporations and a leader in the development and production of engineered components and materials.

In 1665, King Louis XIV signed the letters patent, leading to the creation of Saint-Gobain on an industrial basis. Among the company's earlier and more notable projects was the manufacturing of 357 mirrors for the Hall of Mirrors in the Palace of Versailles. From these glassmaking origins, Saint-Gobain continues its long history of developing new and innovative materials and products through arduous research.



With more than 170,000 employees, operations in 67 countries and eight major cross-business research centers that serve all activities, Saint-Gobain provides complete and thorough service to our customers, beginning with our experienced design engineering team, moving to our high-tech labs for testing and research and development, and continuing on to the manufacturing floor.

As a key ingredient in the wellbeing of each of us and the future of all, we have devoted much of our resources to creating strong research and development centers and establishing partnerships with prestigious universities and laboratories. Our commitment to innovation has resulted in the rapid progression of new Saint-Gobain products that did not exist five years ago.

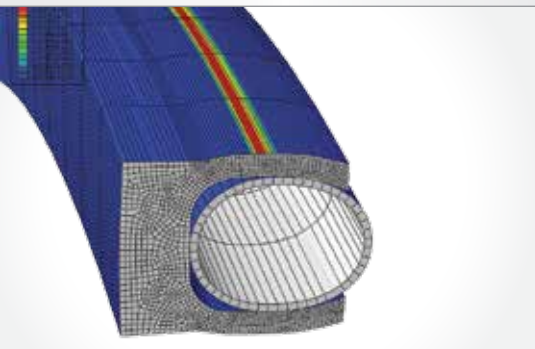

Saint-Gobain is among the global leaders in each of its businesses: construction products, building distribution and innovative materials, including high-performance seals. Our seals are manufactured throughout the world with sites located in the Americas, Europe and Asia.

With a strong history of innovation, Omniseal Solutions is dedicated to providing the most technologically advanced products on the market today and finding solutions for the future.

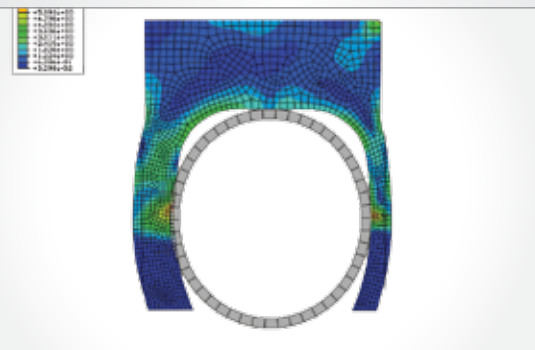

Saint-Gobain Group Headquarters, France

A Tour of Our Capabilities

Omiseal Solutions' global presence allows us to manufacture Omiseal® spring-energized seals throughout the world, with sites located in Garden Grove, California, USA; Kontich, Belgium; Kolo, Poland; Willich, Germany; Minhang, Shanghai, China; Suwa, Japan and Vinhedo, Brazil. To further support your needs we also have a technical office available in Vimercate, Italy. The majority of our products are custom designed through careful and detailed collaboration with each customer, giving them access to the market-leading engineering, research and customer service expertise of our organization.

We are proud of our more than 50 years of experience in manufacturing, along with our spirit of continuous improvement utilizing WCM, 5S, Kaizen and Six Sigma, which lead to superior process control, high product quality and consistent performance. As a result of our dedication to excellence, our worldwide facilities are ISO 9001 certified. Our sites in Garden Grove, Kontich, Minhang, Kolo and Willich are also ISO 14001 certified. Additionally, our Garden Grove and Bristol sites are certified for AS9100, the Kontich site for EN9100 and the Willich site for TS16949 and OHSAS 18001.

Design Engineering

- 3D modeling
- Finite Element Analysis (FEA)
- CAD drawings
- FEA-based spring force calculator

R&D, Lab and Testing

- DMA (Dynamic Mechanical Analyzer), TMA (Thermomechanical Analyzer), TGA (Thermogravimetric Analyzer) and DSC (Differential Scanning Calorimetry)
- FTIR (Fourier Transform Infrared Spectroscopy) and SEM (Scanning Electron Microscopy), Malvern Particle Analyzer, Digital Microscopes and Surface Finish Profilometer
- Tribological Material Testing; Mechanical, Electrical and Optical Testing; and EMI/RFI Testing
- Blending and Molding, High-Speed Rotary Test Rigs and High Pressure Hydraulic Test Chamber

Manufacturing

- Metal fabrication
- Multi-axis precision manufacturing
- Injection and co-injection molding, liquid injection molding, hot and cold compression molding, automatic molding, hot and cold isostatic molding
- Direct forming
- Tool design and fabrication
- Coiling/winding and punching
- Casting and coating
- Skiving and sintering
- Rapid prototyping



Garden Grove, California, USA



Kontich, Belgium



Minhang, Shanghai, China



Kolo, Poland



Suwa, Japan



Willich, Germany



Vinhedo, Brazil

Table of Contents



Welcome to the Omniseal Solutions' World	2
A Tour of Our Capabilities	3
When Our Spring-Energized Seals Journey Began	5
Our Spring-Energized Seals and Their Part in History	6
Omniseal® Elements	
How Our Omniseal® Spring-Energized Seals Work	7
Our Seal Jacket Materials	8
Our Investment in Industry-Recognized Material and Qualification Standards	11
Our Seal Design Variations	13
Our Spring-Energizer Materials	14
Seal Function and Motion	15
Friction and Rotary Motion	16
Temperature, Pressure and Extrusion Gap	17
Hardware, Finish and Hardness	19
Gland Design	20
Markets and Case Studies	
Oil & Gas	22
Aerospace	25
Life Sciences	28
Electronics	30
Omniseal® Selection Guide	32
How to Order Our Standard Omniseal® Products	34
Radial Seal and Face Seal	
400A Series	36
103A Series	37
Spring Ring II Series	38
APS Series	39
RP II Series	40
RACO® 1100A Series	41
Omniseal® Back-Up Rings	42
How to Order Our Back-Up Ring Products	43
Gland Dimensions	
Radial Seal AS4716	44
Radial Seal MIL-G-5514 and Industrial	47
Inside Face Seal	52
Outside Face Seal	55
Omniseal® Installation	58
Special Seal Designs	59
Chemical Compatability Guide	61
Application Data Form	66
Warranty	67
Terms and Conditions	68
Product Line and Market Summary	70

When Our Spring-Energized Seals (SES) Journey Began

What Is the Omniseal® Product Line?

Omniseal® seals are the Omniseal Solutions' product family of spring-energized PTFE seals made from high-performance polymer materials.

In the early 1950s, Omniseal® seals were first developed by three separate entrepreneurs in Southern California, each introducing a unique design: Omniseal®, TEC Ring and RACO® seals. These seals were developed to provide improved performance over soft elastomeric seals and hard metal gaskets in applications involving cryogenic liquid propellants in various rocket engine programs. Omniseal® seals helped to solve sealing problems from highly aggressive chemicals at very low temperatures where conventional seals had failed.

In the 1960s and 1970s, the Fluorocarbon Company (which later became Furon), began to purchase Omniseal® designs and firms that manufactured these seals. Furon continued to develop and improve these spring-energized seals in order to handle extreme sealing requirements for the commercial aircraft industry. In 1999, Compagnie de Saint-Gobain purchased Furon, giving our French industrial firm a leading role in the fast-growing high-performance plastics and sealing business. Already well known for its glass and ceramics, Saint-Gobain's acquisition of Furon gave it a more diversified portfolio of products.

Since this acquisition, Omniseal Solutions continues to develop its patented Omniseal® spring-energized seals product line, proven to be effective solutions in multiple industries.



Our Spring-Energized Seals and Their Part in History



Hardware that was built for space vehicles in the Apollo moon exploration program contained a variety of Omniseal® products. The Lunar Lander at the Smithsonian National Air and Space Museum in Washington, D.C., displays our RACO® seal (a design within the Omniseal® product family), which was used to seal the triangular shaped window on the space vehicle.



Omniseal® seals were designed and used in the first space shuttle launched in 1981 by NASA as part of their STS (Space Transportation System) program. Since that time, our seals have been launched into space in 132 shuttle missions and included in 25 critical applications in the main engine, life support systems, hypergolic fuels and external tank. Our seals have traveled more than 500 million miles.



As the first probe from Earth to land intact on Mars, the Viking Mars Lander's sampling chambers where mission critical experiments were conducted contained RACO® seals. RACO® seals were substituted for metal seals which failed leakage tests just months short of vehicle launch.

Proven in the Past ...

Having proved that our Omniseal® product line can handle the most extreme environments in the aerospace industry, Omniseal Solutions looked to assist other industries such as oil and gas, automotive, electronics, industrial and life sciences. Within those industries, we were also successful in addressing critical issues for our customers due to our custom designs, engineer-to-engineer collaboration, and research and development resources. In the past we have proven to be the right partner for sealing and polymer solutions, and we are prepared to assist our customers with their future goals.

... Prepared for the Future

How Our Omniseal® Spring-Energized Seals Work



Omniseal Solutions
SAINT-GOBAIN

The Omniseal® spring-energized seal is a spring-actuated, pressure-assisted sealing device consisting of a PTFE (or other polymer) jacket partially encapsulating a corrosion-resistant metal spring energizer.

When the Omniseal® seal is seated in the gland, the spring is under compression, forcing the jacket lips against the gland walls and thereby creating a leak-tight seal. The spring provides permanent resilience to the seal jacket and compensates for material wear and hardware misalignment or eccentricity. System pressure also assists in energizing the seal jacket. Spring loading assisted by system pressure provides effective sealing in both low and high-pressure operating environments.

Omniseal® jackets are precision machined from PTFE, filled PTFE composites and other high-performance polymers. An Omniseal® seal with a PTFE jacket functions at temperatures ranging from cryogenic to 572°F (300°C) and is inert to virtually all chemicals except molten alkali metals, fluorine gas at high temperature and chlorine trifluoride (ClF₃).

Omniseal® products are available with a variety of spring energizers, each with characteristics that meet specific requirements. Spring loading can be engineered to meet critical low friction requirements in dynamic applications, or extremely high loading often required for cryogenic sealing. Springs are fabricated from corrosion-resistant metals such as 300 Series and 17-7 PH stainless steels, Elgiloy®, Hastelloy® and Inconel®. Omniseal® products with metal springs have unlimited shelf life and are not subject to age controls normally imposed on elastomeric seals.

Seals with elastomer O-rings used as energizers – made from such materials as nitrile, silicone, FKM and OmniFlex™ – are also available by contacting our manufacturing site. The geometry of the Omniseal® seal installed in a gland provides positive resistance to torsional or spiral failures often found in O-rings.

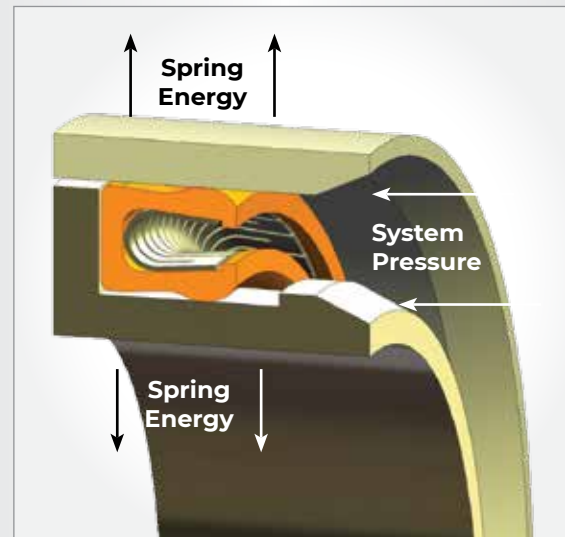
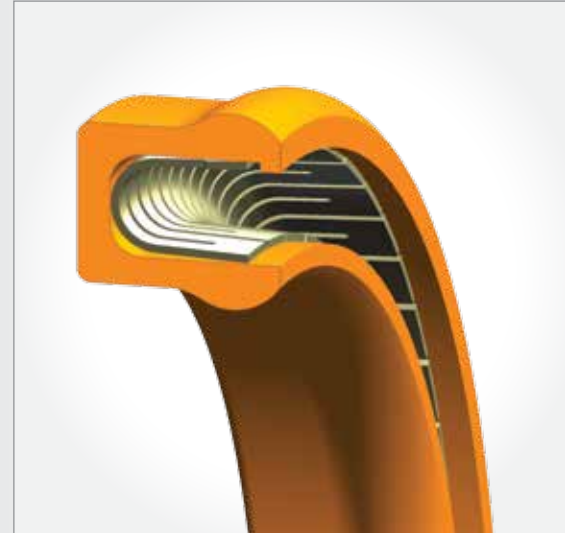

Omniseal® 400A seal in working conditions

Our Seal Jacket Materials

Omniseal Solutions' high-performance polymer compounds, which make up the seal jackets, are made from high-performance polymer resins that are compounded and processed for optimum performance in a wide variety of sealing environments. The materials listed below are our most commonly recommended compounds and are suitable for most applications. Over the years, Omniseal Solutions has developed more than 500 blends for use in unique sealing applications, and we are continually formulating and developing new materials.

MATERIAL CODES AND PROPERTIES

Material Code	Color	Description and Recommended Use	Temperature Range		Coefficient of Friction	Wear Factor*	Tensile Strength (psi/MPa)	Elongation (%)	Hardness (Shore D)
			°F	°C					
A01	White	Virgin PTFE. Excellent for static and light to moderate dynamic service. Limited wear and heat resistance. Low gas permeability. Good cryogenic properties. Moderate to hard vacuum service. FDA compliant.	-346 to +500	-210 to +260	0.09	7,500	4,000 (27.6)	300	58
A02	White	Modified PTFE. Excellent for light to moderate dynamic and static service. Limited wear and heat resistance. Low gas permeability. Good cryogenic properties. Moderate to hard vacuum service. FDA compliant. Improved creep and extrusion resistance.	-346 to +572	-210 to +300	0.09	6,000	4,800 (33.1)	450	58
A05	Black	Polymer Filled PTFE. Excellent wear material for higher temperatures, pressures and speeds. Excellent in water and water-based solutions. Superior in dry or poor lubricated applications. Can be abrasive running against soft metals.	-346 to +572	-210 to +300	0.09	1	2,000 (13.8)	170	64
A08	Tan	Polymer Filled PTFE. Superior heat and wear resistance. Non-abrasive. Recommended for moderate to high speed dynamic service running against soft metals. Not recommended for applications with steam.	-346 to +572	-210 to +300	0.15	2	3,000 (20.7)	230	60
A09	Gold	Formulated UHMW-PE. Extremely tough, long wearing but limited heat and chemical resistance. Particularly suitable for abrasive media. Recommended for long wear life under severe conditions.	-450 to +180	-268 to +82	0.11	9	4,500 (31.0)	230	61
A11	Clear	Virgin PTFE. Thermoplastic with superior resistance to nuclear radiation but limited heat and wear resistance. Not recommended for general purpose sealing.	-150 to +300	-101 to +149	0.50	150	5,600 (38.6)	300	72

* Wear Factor: 1 = Excellent, 15,000 = Poor

MATERIAL CODES AND PROPERTIES

Material Code	Color	Description and Recommended Use	Temperature Range		Coefficient of Friction	Wear Factor*	Tensile Strength (psi/MPa)	Elongation (%)	Hardness (Shore D)
			°F	°C					
A12	Gold	Polymer Filled PTFE. Tough, long wearing, heat resistant. Very low friction. Excellent for dry running applications against soft surfaces. Excellent materials for reciprocating applications.	-346 to +572	-210 to +300	0.09	9	2,000 (13.8)	180	60
A15	Gray	Lubricated Glass Filled PTFE. Similar to A27 material but somewhat softer for improved sealing at low pressure. Can be abrasive running against soft metals.	-346 to +572	-210 to +300	0.09	5	3,400 (23.4)	230	58
A16	Gray	Lubricated Organic Filled PTFE. Excellent general purpose material for heat and wear resistance. Recommended for dry and poorly lubricated applications. Particularly suitable for water and steam service.	-346 to +572	-210 to +300	0.09	12	3,000 (20.7)	200	60
A17	White	Formulated UHMW-PE. Extremely good wear and abrasion resistance, but limited heat and chemical resistance. FDA compliant.	-240 to +180	-150 to +82	0.11	9	5,400 (37.2)	450	62
A21	Black	Lubricated Organic Filled PTFE. Similar to A16 material but increased hardness and wear resistance. Excellent in steam and water under severe conditions. Improved creep and extrusion resistance at higher temperature. Good for back-up rings.	-346 to +572	-210 to +300	0.10	6	1,800 (12.4)	65	65
Meldin® 5301	Tan	Virgin PEEK. High modulus material with excellent high temperature resistance. Recommended for back-up rings and for special applications.	-346 to +572	-210 to +300	0.40	20	13,780 (95.0)	30	90
A27	Gray	Lubricated Glass Filled PTFE. Tough, long wearing, heat resistant. Recommended for high pressure hydraulic service. Can be abrasive running against soft metals at high surface speeds.	-346 to +572	-210 to +300	0.09	9	3,300 (22.8)	280	58
A30	Yellow	Glass Formulated PTFE. Excellent heat, wear and chemical resistance. Good cryogenic properties. Can be abrasive running against soft metals at high speeds. Excellent material for back-up rings.	-346 to +572	-210 to +300	0.09	6	2,700 (18.6)	220	60

* Wear Factor: 1 = Excellent, 15,000 = Poor

MATERIAL CODES AND PROPERTIES

Material Code	Color	Description and Recommended Use	Temperature Range		Coefficient of Friction	Wear Factor*	Tensile Strength (psi/MPa)	Elongation (%)	Hardness (Shore D)
			°F	°C					
A40	Tan	Polymer Filled PTFE. Good wear resistant material for medium hard counterfaces. Caution when used in wet applications. FDA compliant.	-346 to +572	-210 to +300	0.10	6	2,500 (17.2)	175	63
A41	Black	Modified Filled PTFE. Excellent all purpose high wear material. Best for dynamic applications running on moderate to hard surfaces.	-346 to +572	-210 to +300	0.09	30	2,600 (17.9)	135	60
A42	Black	Lubricated Formulated PTFE. Excellent general purpose material with good heat and wear resistance. Non-abrasive. Compatible with all hydraulic fluids and most chemicals. Good in water and non-lubricating fluids.	-346 to +572	-210 to +300	0.09	30	1,800 (12.4)	90	60
A45	Brown	Polymer Filled PTFE. Excellent wear material for higher temperatures, pressures and speeds. Superior in dry or poor lubricated applications. FDA compliant.	-346 to +572	-210 to +300	0.09	1	1,900 (13.1)	300	55
A46	White	Filled PTFE. Good wear resistant material against all stainless steel counterfaces. May be used in contact with food. FDA compliant.	-346 to +572	-210 to +300	0.20	15	2,000 (13.8)	175	60
A47	White	Filled PTFE. Very good wear resistant material under wet or lubricated conditions. May be used in contact with food. FDA compliant.	-346 to +572	-210 to +300	0.11	9	1,200 (8.3)	90	63
A56	Black	Proprietary PTFE. Outstanding heat and chemical resistance. Highly conductive material.	-150 to +400	-101 to +204	0.21	32	3,500 (24.1)	250	65
A68	Black	Filled PTFE. Excellent for dynamic sealing in ceramic surfaces. Excellent wear resistance in water, dry and lubricated environments.	-346 to +572	-210 to +300	0.36	5	2,000 (13.8)	200	60
A90	Dim Gray	Proprietary PTFE. Good sealing capabilities at elevated temperatures and excellent for static or low dynamic service.	Cryo. to +662	Cryo. to +350	0.38	74.5	1,200 (8.3)	43	60

* Wear Factor: 1 = Excellent, 15,000 = Poor

Our Investment in Industry-Recognized Material and Qualification Standards

Material Properties and Qualifications

The demand for additional qualifications has been increasing over time due to stringent environmental requirements. Omniseal Solutions' Research and Development department has been continuously working on the development of new materials and qualifications in order to meet the new industry standards of tomorrow. This has resulted in our materials being qualified according to international standards applicable for different industries, several of which are detailed below. For more information on our other qualifications, please view our website at www.omniseal-solutions.com or contact us at help@omniseal-solutions.com.

NORSOK M-710 and API 6A Requirements for the Oil and Gas Industry

In the 1970s, Omniseal Solutions introduced Omniseal® spring-energized seals to the oil and gas market in order to solve reliability and durability problems caused by the severe limitations of elastomeric seals. These seals, which had already proven themselves extensively in the aerospace industry, addressed critical issues including aggressive media, sour gas environment, resistance to rapid gas decompression and extreme operating conditions. Over the years, we have built unique expertise in designing high-performance polymer components that meet the most difficult challenges.

Today, Omniseal Solutions has more than 30 high-performance polymer materials available that are qualified to the NORSOK M-710 standard, which describes the required physical tests for sealing materials. Most tests were undertaken at our R&D facilities, while the aging tests were carried out by the Element Hitchin/MERL independent laboratory in the United Kingdom. The aging results can lead to an estimation of service life for materials in sour applications as well as a more general assessment of their suitability for sour service. In this qualification process, high-performance polymer materials were subjected to extreme temperature and high percentages of hydrogen sulfide up to 25% H₂S, providing new insights into the properties of these high performance compounds. This information will be used for the development of materials which can be used under even more demanding environments.

All of our high-performance polymer and Meldin® materials that successfully passed the NORSOK qualification are available. The metal energizers are NACE-approved materials for use in sour gas service. In addition, we have materials qualified to API 6A F1.13.5.2 sour immersion testing of materials in fluid HH at 392°F (200°C).

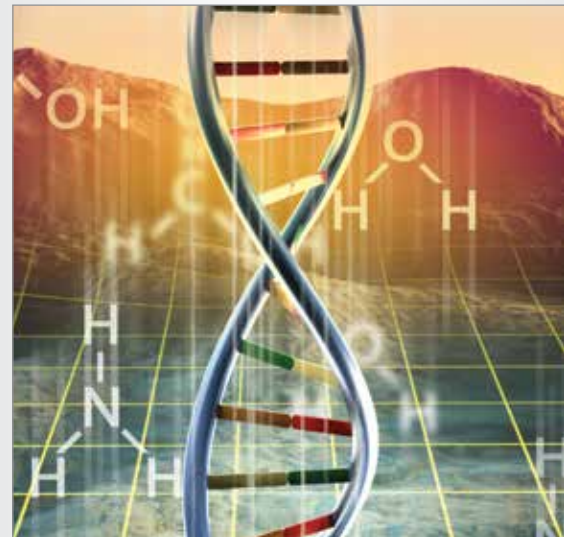

Our Investment in Industry-Recognized Material and Qualification Standards

Material Compliance and Regulations for the Life Science Industry

From material selection to clean room operations, Omniseal Solutions offers the technology and infrastructure to support today's life science customer. Our extensive material catalogue includes different materials such as PTFE, PEEK, PCTFE, UHMW-PE and PFA based compounds that are compliant with one or more life sciences regulations. Please refer to the table below.

All listed FDA compliant, high-performance polymer materials are approved for repeated contact with food or drugs for oral consumption under title 21 CFR of the United States Food and Drug Administration (FDA). The awareness for safe direct food contact has grown worldwide and therefore different regulations are available. As a global developer and manufacturer of sealing elements for the life science industry, it is imperative that we have materials available that comply not only with the FDA but also with Direct Food Contact Regulation 1935/2004 & 10/2011 in Europe.

In addition, Omniseal Solutions offers high-performance polymer materials with full USP Class VI certification that comply with stringent disposable and reusable medical device requirements. The United States Pharmacopeia (USP) is a voluntary, not-for-profit organization that promotes the public health by establishing and disseminating officially recognized standards of quality. Plastics are qualified into one of six classes, each requiring different levels of testing. Class VI requires the most extensive testing and is the most challenging to pass.

Many applications in different industries deal with extreme chemical environments. Whether the media is alkaline, acidic or a unique solvent, Omniseal Solutions offers a material compound to meet your specific chemical needs, including A02, A21 and Rulon® LR solutions, which are BAM certified.

DIRECT CONTACT MATERIAL PROPERTIES



Material Code	FDA Compliant	EU 1935/2004 10/2011	USP Class VI
A01	•		
A02	•		
A06	•		
A09	•		•
A12			•
A20	•		•
Meldin® 5301	•		
A23	•		
A40	•	Simulant A, B, D2	
A41			•
A45	•		
A46	•	Simulant A, D2	•
A47	•	Simulant D2	•
A66			•
A79	•		

Our Seal Design Variations



Omniseal® 400A Spring Design		Omniseal® 103A Spring Design	
Omniseal® Spring Ring II Design		Omniseal® APS Spring Design	
Omniseal® RP II Spring Design		Omniseal® RACO® 1100A Spring Design	
Skived Lip	Extended Heel	Flanged Heel	
<p>All Omniseal® designs except Omniseal® RP II can be supplied with a sharp edge on either the I.D. or O.D. sealing lip. This edge provides a scraper/wiper action for sealing abrasive or viscous media. It may also be used as an environmental excluder.</p>	<p>Omniseal® products can be supplied with an extended heel section for improved resistance to extrusion at high temperatures and/or high pressures.</p>	<p>The flanged heel design is recommended for rotary/oscillatory shaft applications. The flange is clamped in the seal housing to prevent the seal from turning with the shaft.</p>	



Omniseal Solutions offers the most complete line of spring-energizer configurations for various industries.

Optional Energizers

ELASTOMER ENERGIZERS



Omniseal® 103A seals may be ordered with optional elastomeric O-ring energizers in place of the metallic spring. A wide variety of elastomers, such as OmniFlex™, nitrile, FKM and silicone are available.

RTV SILICONE FILLED ENERGIZERS



Omniseal® 400A seals can be supplied with an FDA-approved grade of RTV silicone filled into the spring cavity. The elastomer ensures that no contaminants become trapped in the spring cavity, allowing the seal to be used in food processing and clean-in-place applications. Other materials are also available.

The metallic spring energizers available with Omniseal® seals are listed in the chart below. Because of the nearly infinite variety of fluid media that may be encountered by the seals, no specific recommendations are made. The various stainless steels listed are compatible with most fluids. For questions or more information about media compatibility, please contact our Technical Support team at help@omniseal-solutions.com or refer to the back page for site contact information.

SPRING COMPARISON: LOAD VS. DEFLECTION

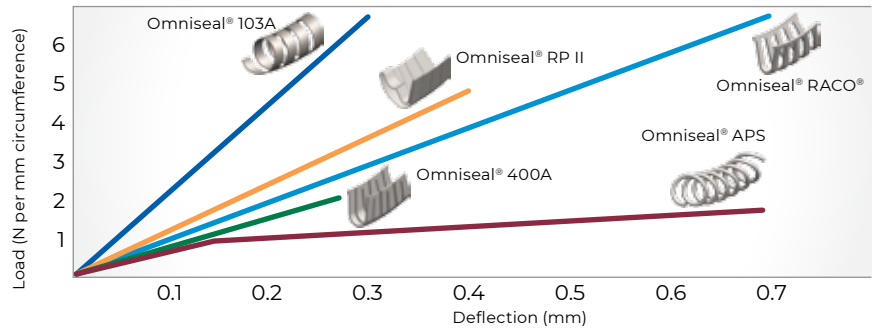

ENERGIZER OPTIONS WITH SEALS



Code No.	Description	Omniseal® APS	Omniseal® Spring Ring II	Omniseal® 400A	Omniseal® 103A	Omniseal® RP II	Omniseal® RACO® 1100A
		p. 39	p. 38	p. 36	p. 37	p. 40	p. 41
01	301 Stainless Steel		Standard	.	.	Standard	Standard
02	Inconel® 718						.
04	304 Stainless Steel			Standard	.	.	
05	Elgiloy®			.	.		.
06	316 Stainless Steel	
07	17/7 PH Stainless Steel				Standard		
08	Hastelloy® C276	
09	302 Stainless Steel	Standard				.	

· Optional selections for all sizes. Please contact our Technical Support team for more information.
 Note: Other metallic spring energizers are available. For information regarding design requirements, specific seal designs, unique applications and additional data specifications, contact our Technical Support team.

Seal Function and Motion

Static and Dynamic Applications

There are two basic types of sealing applications: static and dynamic, in which at least two hardware surfaces come into contact with one another.

In static applications, there is essentially no relative motion between the hardware surfaces. A typical example is flanges that are bolted together. Omniseal Solutions offers face seals in such applications.

In dynamic applications, at least one surface is in motion relative to the other. A typical example is a hydraulic cylinder with shaft and bore. Further, there are two directions of motion in dynamic application: reciprocating or linear motion, and rotary (including oscillating) motion. We offer radial seals (rod seals and piston seals) in such applications.

Occasionally, the application may be a combination of both static and dynamic. Please see our application recommendations below or contact our Technical Support team at help@omniseal-solutions.com. You may also refer to the back page for specific site contact information.

Radial and Face Sealing

Based on the hardware configuration and location of seal glands, sealing can be either radial or axial (face sealing).

Radial sealing has glands that compress seals in a radial direction. Male glands are machined in the shaft, while female glands are machined in the bore. Radial sealing is usually, but not always, dynamic. We also offer rod seals and piston seals for these applications.

Axial sealing has glands that compress seals parallel to the axis of the seal. Glands are machined on the face of the hardware. Axial sealing is usually, but not always, static. We offer inside and outside face seals in such applications.

OMNISEAL® APPLICATION RECOMMENDATIONS

	Radial Sealing			Face Sealing
Static Application	Omniseal® 103A			Omniseal® 103A / RACO® 1100A
Dynamic Application	Reciprocating	Omniseal® 400A / APS	Omniseal® 103A / RP II	Omniseal® 400A / APS / RACO™ 1100A / 103A
	Rotary	Moderate Speed	Flanged Omniseal® 400A / APS	
Slow Speed		Flanged Omniseal® 103A	Flanged Omniseal® RP II	

DYNAMIC RADIAL SEAL

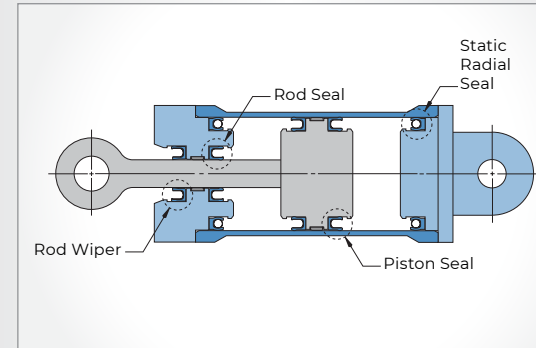

STATIC INSIDE FACE SEAL

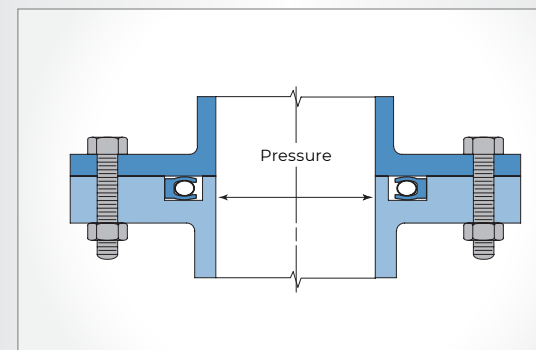

STATIC OUTSIDE FACE SEAL

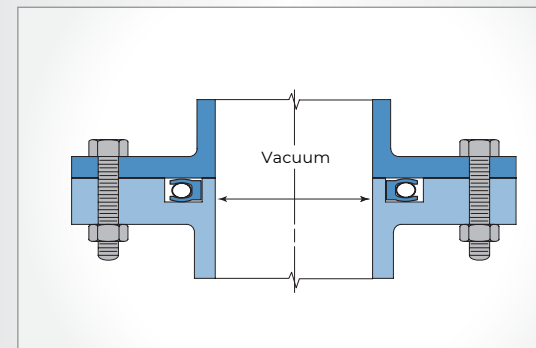

Friction and Rotary Motion

TYPICAL SPRING LOAD RANGES

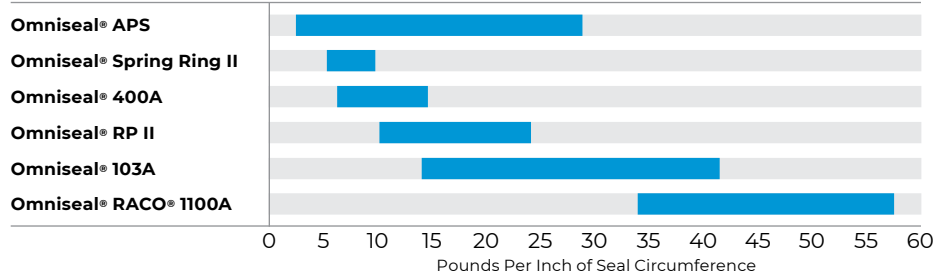

NOTE: The values above are for standard spring material and thicknesses. Other materials and spring thicknesses may be substituted; consult our Technical Support team for availability.

Friction, a measurement of the resistance to sliding between a seal and hardware surfaces, is directly related to the seal material's coefficient of friction and the normal load. Other factors that affect friction are lubrication, possible misalignment, pressure, temperature and hardware surface finishes. Information in the charts and formulas on this page can be used to calculate an approximate friction value for non-lubricated conditions. Lubrication provided by the media may produce lower frictional values.

It is difficult to predict how the running and break-out friction values will differ without testing under actual working conditions. OmniSeal Solutions manufactures a variety of springs with lower or higher loads than those shown on this page. In addition, we can develop special springs to meet other performance needs. For assistance with applications where friction is critical, please contact our Technical Support team at help@omniseal-solutions.com. You may also refer to the back page for specific site contact information.

The approximate total load of an OmniSeal® seal can be calculated by adding the pressure load found in the "Pressure Load" chart shown at right to the average spring load shown in the "Typical Spring Load Ranges" chart above. For rotary motion, use the chart below right to qualify OmniSeal® products for continuous rotary applications.

PRESSURE LOAD

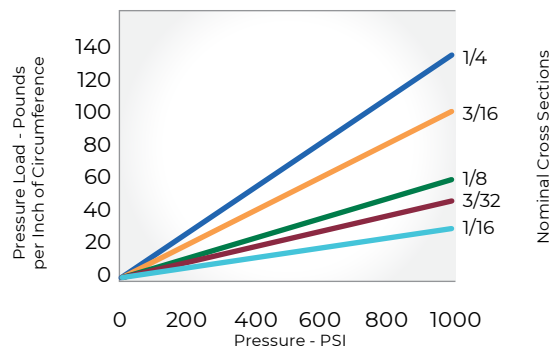

SURFACE SPEED AND PRESSURE

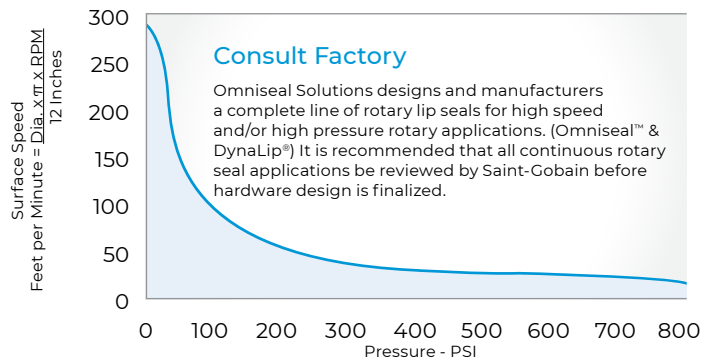

F = Total unit load – Pounds per inch of circumference (pressure load + spring load)

D = Diameter of dynamic surface

R = D/2 (Radius)

μ = Material coefficient of friction

Linear Friction (Pounds) = $F \times D \times \pi \times \mu$

Frictional Torque (Inch-Pounds) = $F \times D \times \pi \times \mu \times R$

Temperature, Pressure and Extrusion Gap

MAXIMUM RECOMMENDED EXTRUSION GAP

(Omniseal® 103A shown for illustration only)		A*	B*	C*	D*
 G Width	Unfilled	.004	.003	.002	—
	Filled	.006	.004	.003	—
 G ₁ Width	Unfilled	.006	.004	.003	—
	Filled	.008	.006	.004	.003
 G ₂ Width	Unfilled	.008	.006	.004	.003
	Filled	.010	.008	.006	.004
 G ₂ Width	Unfilled	.010	.008	.006	.004
	Filled	.014	.010	.008	.006

Note: Consult Technical Support for extrusion gap information regarding specific applications.
*Refer to page 18.

EXTRUSION GAP DETAIL

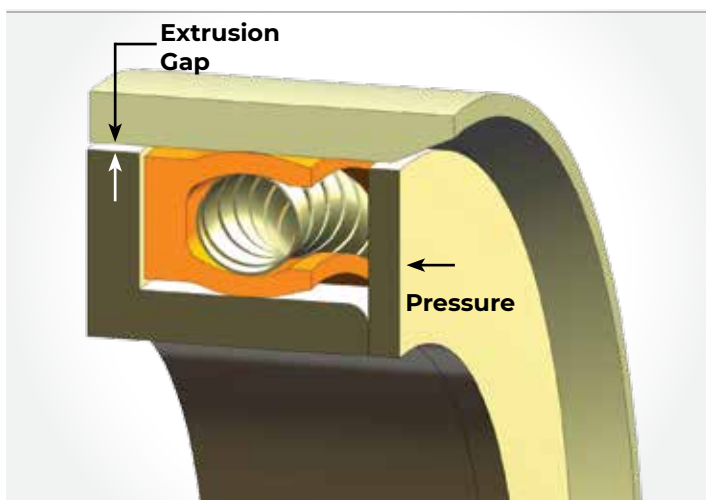

The size of the extrusion gap behind the seal is critical when sealing against high pressures and/or high temperatures. The extrusion gap is the clearance between the member hardware. Hardware designs without bearing or centering devices must take into consideration the diametrical clearance as the maximum extrusion gap. The combination of high pressures and/or high temperatures and excessive clearance can allow the seal jacket to extrude into the gap, causing premature failure.

The extrusion gap should be held to the minimum, and should not exceed the values shown in the table. Increasing the heel thickness of the seal improves resistance to extrusion. The extrusion gap can also be bridged using a separate back-up ring arrangement.

G Width: Gland width for standard seals without any back-up ring

G₁ Width: Gland width for extended heel and flanged heel seals without any back-up ring

G₂ Width: Gland width for standard seals using a back-up ring



Temperature, Pressure and Extrusion Gap

Cryogenic Sealing

Cold temperatures below -40°F (-40°C) will cause PTFE and other polymer sealing materials to shrink and harden, and may compromise the spring load and frictional characteristics of the Omniseal® spring-energized seal. Although face seals are less affected than radial seals, please consult our Technical Support team at help@omniseal-solutions.com before selecting an Omniseal® seal for any cryogenic application.

Seal Design Versus Temperature

Typically, seal jacket materials become somewhat harder at cold temperatures and may soften to some extent at high temperatures (see material list on pages 8-10 for temperature ranges). The spring energizer compensates for these conditions. If your seal design selection does not agree with the graph above, please consult our Technical Support at help@omniseal-solutions.com.

TEMPERATURE VERSUS PRESSURE AND SEAL DESIGN

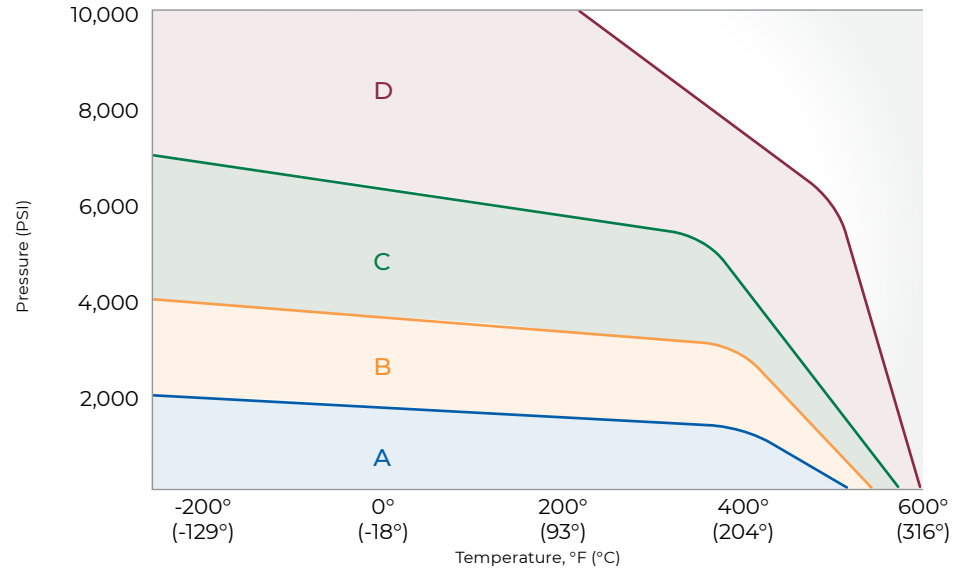

Consult Technical Support for "D" range or above. Please also refer to the Maximum Recommended Extrusion Gap table on page 17, which shows the A, B, C and D values.

SEAL DESIGN VERSUS TEMPERATURE

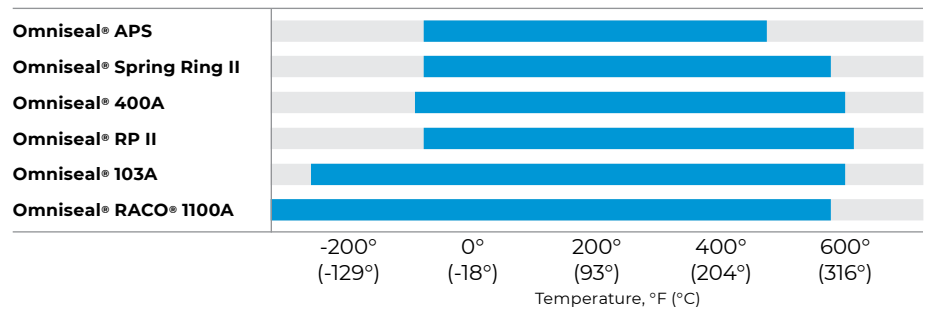

For temperatures below 0°F, contact Technical Support.

HARDWARE SURFACE FINISH RECOMMENDATIONS

Media Sealed	Surface Finish	
	Dynamic Surface	Static Surface
Cryogenics Helium gas Hydrogen gas Freon	4 - 8 μin (0.1 - 0.2 μm) Ra	8 μin (0.2 μm) Ra max
Air Nitrogen gas Argon gas Natural gas Fuel (aircraft, automotive)	6 - 12 μin (0.15 - 0.3 μm) Ra	16 μin (0.4 μm) Ra max
Water Hydraulic oil Crude oil Sealants	8 - 16 μin (0.2 - 0.4 μm) Ra	32 μin (0.8 μm) Ra max

SEAL WEAR IN DYNAMIC SURFACE

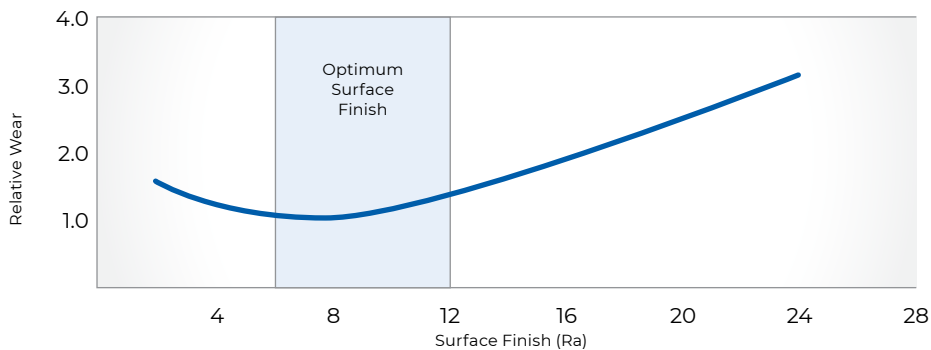

Dynamic Hardware Surface Finish

The surface finish of materials that come into contact with the Omniseal® spring-energized seals influences wear and life expectancy of the jacket material. Mating surfaces that are too rough can create leak paths and may be abrasive to the seal. Generally, smoother surface finish (lower Ra value) corresponds to lower wear, extended seal life and improved overall seal performance.

The transfer of a thin film of PTFE from the Omniseal® jacket to the mating dynamic surface will improve seal life. Although rough finishes wear the jacket material too rapidly, extremely smooth dynamic surfaces prohibit sufficient material transfer to form a thin film. The graph on the left illustrates the effect of surface finish on seal wear.

Static Hardware Surface Finish

In most static sealing applications, better overall sealing performance is achieved with a smoother sealing surface finish. The optimum surface finish for most static sealing applications is 32 μin (0.8 μm) Ra or better. The “lay” on surfaces for static face seals should be concentric. Polishing or machining surfaces should be circular.

Surface Hardness

A 40 Rockwell C hardness or greater is recommended for slow to moderate reciprocating motion. The ideal hardness for moderate to high-speed linear or rotary motion is 58 to 62 Rockwell C. Hard anodized surface finishes must be polished after anodizing.

Gland Design

GLAND WIDTH FOR STANDARD OMNISEAL® SEAL

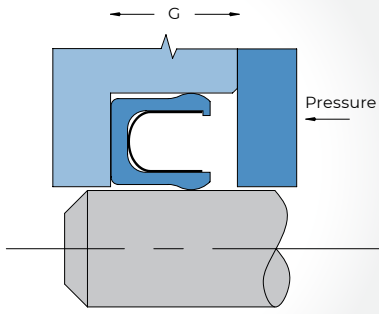

GLAND WIDTH FOR EXTENDED HEEL OMNISEAL® SEAL

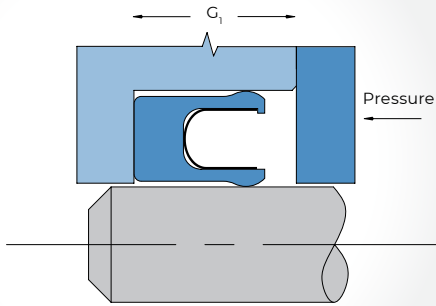

GLAND WIDTH FOR STANDARD OMNISEAL® SEAL PLUS BACK-UP RING

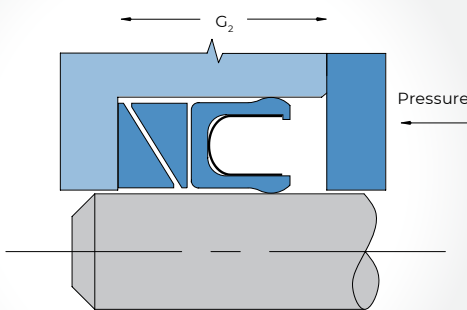

Proper gland geometry in the early stages of design can eliminate installation problems. Utilizing split or separable glands in piston and rod seal applications can eliminate the need for special tools and the need to stretch or compress the Omniseal® seal during installation into the gland.

To minimize stretching or distortion during assembly in non-split glands, the gland side wall on the pressure side can be reduced to provide a partial shoulder to retain the seal. Examples of alternate gland designs, including flanged, are shown below. If stretching into a full groove is unavoidable, consult proper procedures and tools recommended on page 58. Avoid assembling the seal over sharp corners, threads, keyways, etc. When these conditions exist, please use protective tooling.

ROD SEAL AND PISTON SEAL GLAND

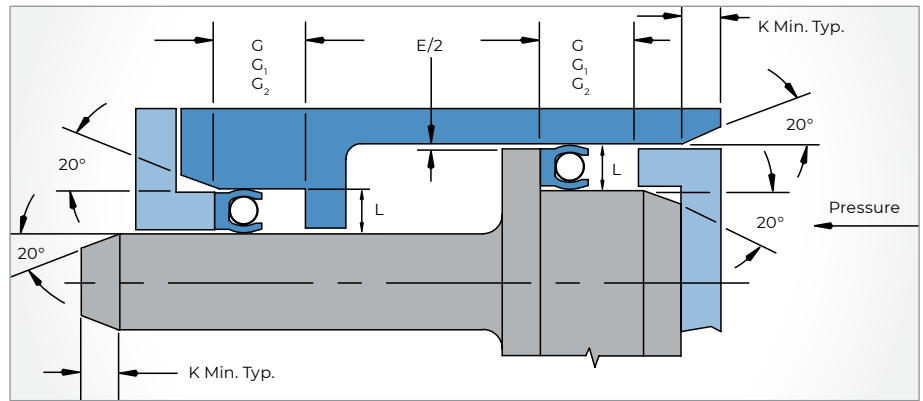

FLANGED SHAFT SEAL GLAND

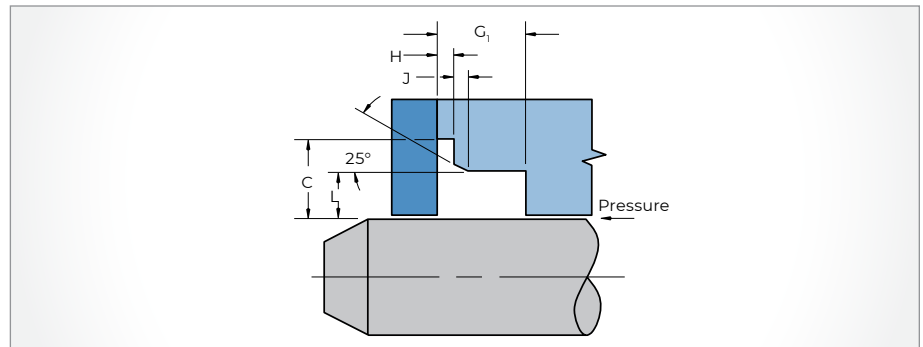

RADIAL SEAL GLAND DIMENSIONS (IN.)

MIL-G-5514/ Industrial and AS4716 Dash No.	Nominal Cross- Section ²	G +0.010 -0.000	G ₁ +0.010 -0.000	G ₂ +0.010 -0.000	K Min.	C ±0.005	H ±0.001	J ±0.005	E Nominal ¹
004 - 045	1/16"	0.094	0.149	0.207	0.040	0.135	0.016	0.030	0.004
106 - 163	3/32"	0.141	0.183	0.245	0.062	0.168	0.023	0.035	0.005
202 - 281	1/8"	0.188	0.235	0.304	0.094	0.217	0.027	0.050	0.006
313 - 381	3/16"	0.281	0.334	0.424	0.125	0.331	0.032	0.070	0.007
409 - 460	1/4"	0.375	0.475	0.579	0.156	0.456	0.047	0.090	0.008

¹See extrusion gap recommendations on page 17

²Nominal cross-section shown as "L" on page 20

Alternate Gland Designs

PISTON SEAL SNAP RING GLAND

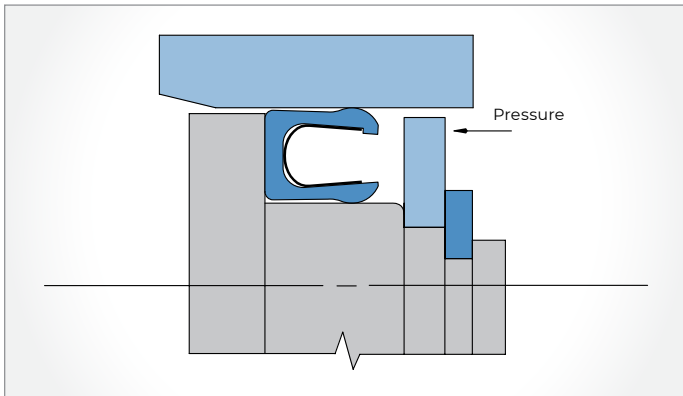

ROD SEAL SNAP RING GLAND

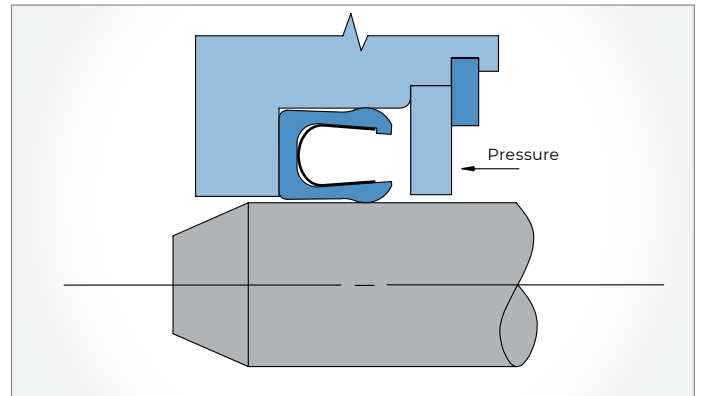

PISTON SEAL REDUCED GLAND

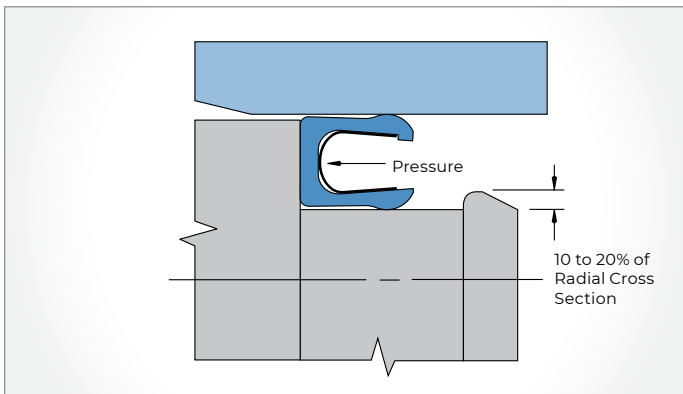

ROD SEAL REDUCED GLAND

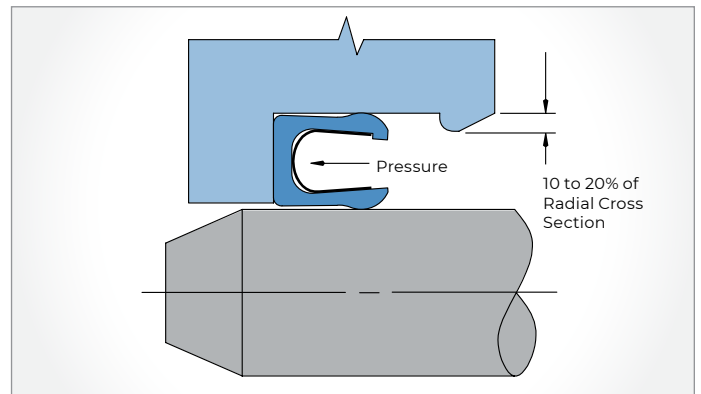

Oil & Gas Market: Where Our Seals Thrive in Aggressive Operating Conditions



For major oil companies, finding the giant fields they need to make their economics viable tend to drive them offshore and into deep water. Therefore, extreme operating conditions arise from the more complex reservoirs. These new requirements inspired Omniseal Solutions to design a series of innovative sealing solutions that consistently and reliably meet the ever-increasing requirements of high-performance equipment manufacturers.

Features/Benefits

- Deep and ultra-deepwater production
- High pressure and high temperature (HPHT)
- Harsh chemicals
- Rapid Gas Decompression resistance
- Long durability at extreme temperature and sour gas concentrations
- Proprietary polymer compounds qualified to NORSOK M-710 and to API 6A F.1.13 specifications
- Cryogenic temperatures
- Design complaint with Fugitive Emission international standards ISO15848 and Shell MESC SPE 77-312



Successful Oil and Gas Applications

- Engineered subsea and topside valves
- Hydraulic couplings
- FPSO turret swivels
- Pumps and compressors
- Gas turbines
- Transfer systems
- Subsea equipment



On/off Valves Fugitive Emission

Product:	Omniseal® 103A custom design and V-packings
Specifications:	Fugitive Emissions Standards SHELL MESC SPE 77-312 or ISO15848-1
Typical Temperature:	-58°F (-50°C) to 320°F (160°C)
Typical Pressure:	Pressure up to 15,011 PSI (1,035 BAR)
Leakage Rate:	Class B 10^{-4} mg.s ⁻¹ .m ⁻¹ circ
Endurance:	Class C03; 2,500 cycles
Media:	Oil

Our Added Value +

- Self-lubricating jacket material
- Non-abrasive sealing solution
- NORSOK M-710 materials
- High pressure and high temperature (HPHT) design



Swivel for Marine LNG Loading Arms

Product:	Omniseal® RACO® 1100A custom design
Specifications:	Primary and secondary dynamic face seal
Typical Temperature:	-265°F (-165°C)
Typical Pressure:	290 PSI (20 BAR)
Typical Speed:	Slow angular motion
Media:	Liquefied Natural Gas (LNG)

Our Added Value +

- Self-lubricating jacket material
- Non-abrasive sealing solution
- High-load and high-resilient seal
- Excellent for cryogenic temperatures and uses



Oil & Gas Market: Case Studies



Subsea Valves Ball and Gate Valves for Subsea Production Systems PLETs, PLEMs, Manifolds and Xmas Trees

Product:	Omniseal® 103A custom design
Specifications:	API Spec 17D/ISO 13628, API Spec 6DSS/ISO 14723 API Spec 6A, Appendix F (PR2test)/ISO 10423
Typical Temperature:	Up to 482°F (250°C)
Typical Pressure:	Up to 15,011 PSI (1,035 BAR)

Our Added Value +

- Self-lubricating jacket material
- Non-abrasive sealing solution
- NORSOK M-710 materials
- High pressure and high temperature (HPHT) design
- Reliable and long service life



High-Pressure FPSO Turret Swivel

Product:	Omniseal® 400A and welded PEEK back-up ring
Specifications:	Primary and secondary dynamic face seals, static seals
Typical Temperature:	Up to 248°F (120°C)
Typical Pressure:	6,237 PSI (430 BAR)
Typical Speed:	Slow angular motion (24 in./min. or 0.6 m/min.)
Media:	Oil

Our Added Value +

- Self-lubricating jacket material
- Non-abrasive sealing solution
- NORSOK M-710 materials
- High pressure and high temperature (HPHT) design

Space & Aviation Markets: Where Our Seals Rise to the Most Difficult Challenges

Omniseal Solutions has its richest and oldest history in the space and aviation markets, supplying innovative sealing solutions since 1955. From space programs such as Apollo, Viking and the Space Shuttle to present-day space launch vehicles, Omniseal Solutions has remained a leader in providing spring-energized seals for the aerospace industry for more than 50 years.

A growing requirement for commercial aircraft, military aircraft and launch vehicles is to use lighter weight materials in order to optimize fuel burn and increase payload capability. In addition, jet engines are being designed to operate at higher temperatures in order to increase thrust capabilities and operating efficiencies. We continue to lead the way in the space and aviation industry by providing differentiated solutions for commercial aircraft, military aircraft and launch vehicle applications.

Features/Benefits

- Proven designs and tested solutions
- Maintenance-free solutions
- Lightweight components
- Low- and high-pressure sealing
- Low- and high-temperature resistance
- Elastomer energizers also available

Successful Space & Aviation Applications

- Hydraulic/pneumatic linear actuators
- Gearboxes
- Turbine seals
- Oil sumps
- Landing gears
- Jet engines
- APUs
- Rocket engines
- Launch vehicles



Space & Aviation Markets: Case Studies



Gear Box Shaft

Product:	Omniseal® 400A seal
Specifications:	Sealing of gear box actuator shaft
Typical Temperature:	-58°F (-50°C) to 320°F (160°C)
Typical Pressure:	Up to 18,927 PSI (1,305 BAR)
Leakage Rate:	None
Media:	Various media including water, oil and grease

Our Added Value +

- Spring energizers perform better at low temperature compared to traditional elastomer energizers
- Sealing materials compatible with HVOF wear coatings
- Small seal envelope



Anti-icing Seal in Flight Actuator

Product:	Omniseal® RP II seal
Specifications:	Sealing at extreme temperature
Typical Temperature:	As low as -65°F (-54°C)
Typical Pressure:	Pressure from -25 to 75 PSI (1.7 to 5.2 BAR)
Media:	Rainwater, deicing fluid, hydraulic oils

Our Added Value +

- Prevents ice and snow from moving inside the actuator mechanism
- Effective sealing at low temperature
- High performance in rugged applications

Space & Aviation Markets: Case Studies

Rocket Engine Check Valve

Product:	OmniSeal® 103A anti-blowout seal
Specifications:	Retains pressurized fluid on the high pressure side while preventing blowout of the seal from the housing
Typical Temperature:	-300°F (-184°C) to 122°F (50°C)
Proof Pressure:	3,000 PSI (207 BAR)
Leakage Rate:	None over hundreds of cycles
Media:	Pressurized and liquefied gas



Our Added Value +

- Seal helps to prevent blowout in check valves
- Unique seal design allows the seal to resist deformation resulting from rapid change of pressure across the seal surface
- Seal can operate from cryogenic temperature up to 575°F (320°C)

Secondary Seal in Aircraft APU

Product:	OmniSeal® 400A seal
Specifications:	Sealing inside a mechanical carbon face seal. The seal performs secondary sealing as well as offers a very controlled drag to primary carbon face.
Typical Temperature:	-67°F (-55°C) up to 550°F (288°C)
Differential Pressure:	0.3 to 12 PSI (0.8 BAR)
Media:	Air and oil



Our Added Value +

- The seal can operate effectively over a wide range of temperatures
- Controlled spring force adjusts the carbon face of minor change in differential pressure
- Very thin cross-section minimizes drag

Life Science Market: How Our Seals Operate in Stringent Conditions



For more than 30 years, Omniseal Solutions has been a trusted manufacturing partner to the medical, dental, analytical and pharmaceutical markets. Whether the challenge is caustic chemical, high pressure or cleanliness, we offer a solution to meet your stringent requirements. Our sealing materials offer temperature capability from -450°F (-268°C) to 600°F (316°C) and our seals offer pressure ratings from vacuum up to 50,000 PSI (3,448 BAR).

Features/Benefits

- FDA Title 21 CFR 177.1550 compliance materials
- USP Class VI compliance materials
- Broad chemical compatibility
- Purity and cleanliness through Class 100 and 10K clean room manufacturing
- Critical sealing
- Frictional sealing across a wide range of PV applications



Successful Life Sciences Applications

- HPLC/UHPLC
- Surgical tools
- Autoclave pumps
- Hematology analyzers
- Instrumentation
- Portable oxygen concentrators
- Pharmaceutical manufacturing equipment



Life Science Market: Case Studies

Autoclave Pump

Product:	Omniseal® seal with elastomer energizer
Specifications:	Sealing in saturated steam
Typical Temperature:	70°F to 270°F (21°C to 137°C)
Typical Pressure:	50 PSI (3.5 BAR)
Typical Speed	5,300 RPM (110 FPM)
Typical Motion:	Rotary
Media:	Saturated steam

Our Added Value +

- Works well in dry and poorly lubricated applications
- Accommodates shaft with small diameters and very tight tolerances



HPLC Instrumentation

Product:	Custom Omniseal® seal with APS spring
Specifications:	Sealing at very high pressure
Typical Temperature:	68°F to 104°F (20°C to 40°C)
Typical Pressure:	15,000 PSI (1,034 BAR)
Typical Speed:	1.64 ft./min. (50 cm/min.)
Typical Stroke Length:	0.2 in. (5 mm)
Typical Motion:	Reciprocating
Media:	UHPLC solutions

Our Added Value +

- Long-wearing jacket material
- Low friction
- Constant spring load



Electronics Market: When Our Seals Take Innovation and Technology to a New Level

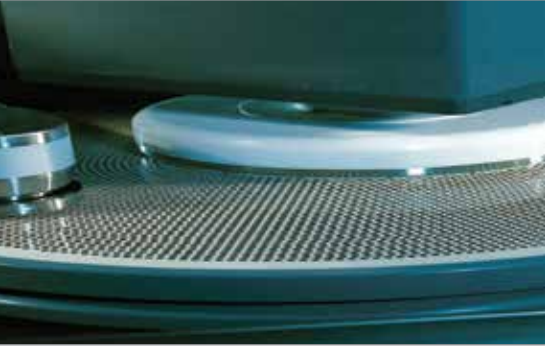

At Omniseal Solutions, quality and innovation are of the utmost importance. We have extensive experience in meeting sealing requirements for various electronics applications. We have seals in many different kinds of semiconductor processing equipment, including etch chambers, deposition chambers, pumps and boosters, cryogenic equipment, vacuum pumps and adhesive dispensing equipment. Our design engineering team and technical staff provide customized solutions that meet your needs. This process includes developing a prototype, testing the solution, manufacturing the part to specifications and delivering it on time.

Our product quality and capabilities are the reason we are the preferred supplier for many large electronics and semiconductor corporations.

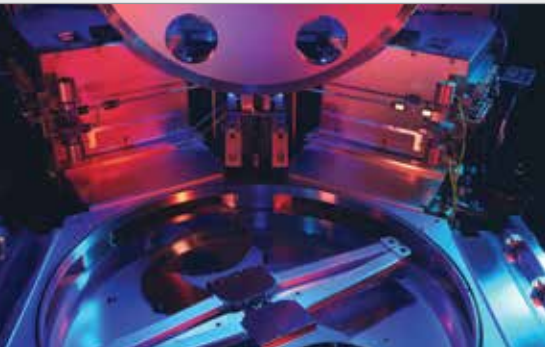

Features/Benefits

- High purity and cleanliness
- Wide range of sealing element sizes and materials
- Provides low outgassing
- Excellent dimensional stability under vacuum and pressure conditions
- Excellent chemical resistance to a wide range of fluids and gases
- Capable of handling wide temperature ranges: cryogenic to 450°F (232°C)
- Functions well under high pressure in excess of 500 PSI (34 BAR)
- Good resistance to both dry and wet process chemistries



Successful Electronics Applications

- Processing pumps and boosters
- Etch, deposition and other chamber lids
- Vacuum pumps
- Cryogenic equipment
- Packaging equipment
- Adhesive dispensing equipment

Micro-E Packaging Plunger Pump

Product:	OmniSeal® 103A radial with skived I.D. lip
Specifications:	Chemically compatible with epoxy resin and installable in a closed groove
Typical Temperature:	Ambient
Typical Pressure:	2,860 PSI (197 BAR)
Media:	Epoxy resin

Our Added Value +

- Excellent wear performance
- Excellent fluid compatibility

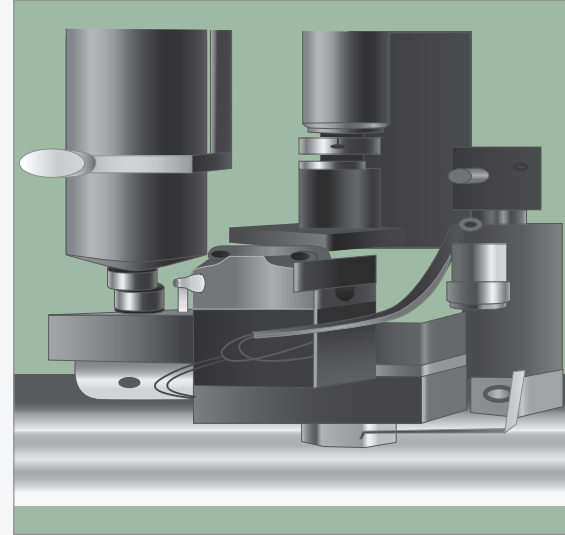

Micro-E Packaging Hotmelt Dispenser

Product:	OmniSeal® 400A radial
Specifications:	Chemically compatible with epoxy resin at high temperature working conditions
Typical Temperature:	392°F (200°C)
Typical Pressure:	2,900 PSI (200 BAR)
Media:	Epoxy resin

Our Added Value +

- Excellent wear performance
- Excellent fluid compatibility
- Low friction seal design

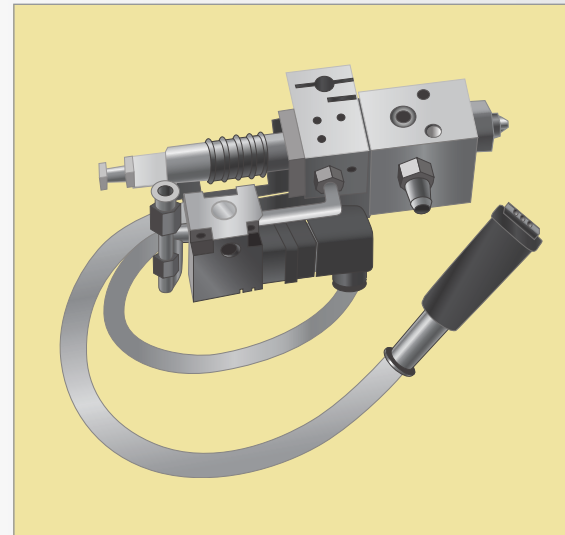

Omniseal® Design Profiles	Seal Designs	Temperature Range		Pressure Capability (psi) Max	Application Service Ratings			Spring Materials Standard
		°F	°C		Static	Reciprocating	Rotary	
400A Standard Heel								
	Rod/Shaft Piston Face	+600° to -85°	+316° to -65°	3,000	G	E	G	304 SS, *301 SS, *316 SS, *Elgiloy®, *Hastelloy® C276
400A Extended Heel								
	Rod/Shaft Piston Face	+600° to -85°	+316° to -65°	6,000	G	E	G	304 SS, *301 SS, *316 SS, *Elgiloy®, *Hastelloy® C276
400A Standard Heel w/ Back-up								
	Rod/Shaft Piston	+600° to -85°	+316° to -65°	10,000 (Specials up to 50,000 psi)	G	E	F	304 SS, *301 SS, *316 SS, *Elgiloy®, *Hastelloy® C276
400A Flanged Heel								
	Rod/Shaft Piston	+575° to -320°	+301° to -196°	3,000	G	E	E	304 SS, *301 SS, *316 SS, *Elgiloy®, *Hastelloy® C276
103A Series								
	Rod/Shaft Piston Face Flanged	+575° to -320°	+301° to -196°	Standard = 3,000 Flanged = 3,000 Extended = 6,000 Back-Up = 10,000	E	F	P	17-7 PH SS, *304 SS, *316 SS, *Elgiloy®, *Hastelloy® C276
Spring Ring II Series								
	Rod/Shaft Piston Flanged	+550° to -65°	+288° to -54°	Standard = 3,000 Flanged = 3,000 Extended = 6,000 Back-Up = 10,000	F	G	G	301 SS, *316 SS
APS Series								
	Rod/Shaft Piston Face Flanged	+475° to -65°	+246° to -54°	Standard = 3,000 Flanged = 3,000 Extended = 6,000 Back-Up = 10,000	F	E	E	302 SS, *316 SS, *Hastelloy® C276
RP II Series								
	Rod/Shaft Piston Flanged	+600° to -65°	+316° to -54°	Standard = 3,000 Flanged = 3,000 Extended = 6,000 Back-Up = 10,000	G	E	F	301 SS, *302 SS, *304 SS, *316 SS
RACO® T100 Series								
	Face	+550° to -425°	+288° to -254°	Standard = 3,000 Extended = 6,000 Back-Up = 10,000	E	P	F	301 SS, *Inconel® 718

P: Poor F: Fair G: Good E: Excellent

*Optional. Consult factory or contact technical support.

**Special cross-sections seals up to 1" are available.



Diameters Min-Max (in.)	Cross Sections (in. nom.)	Standard Gland Sizes	Friction Rating	Recommended Applications	Page Locator
400A Standard Heel					
Rod Seals .185 - 60+ Piston Seals .297 - 60+	1/16 to 1/4**	AS 4716 Industrial MIL-G-5514	Low Moderate	General purpose design for most applications. Best suited for dynamic rod and piston seals when pressure is under 3,000 PSI. Scraper designs can be used as wiper seals or in abrasive medias. Silicone filled spring cavities are available for food processing and clean-in-place applications.	36
400A Extended Heel					
Rod Seals .185 - 60+ Piston Seals .297 - 60+	1/16 to 1/4**	AS 4716 Industrial MIL-G-5514	Low Moderate	Best suited for dynamic rod and piston seals when pressure is under 6,000 PSI or when hardware extrusion gaps combined with high temperature are present. The extra material helps prevent seal failure by filling in the extrusion gap similar to a back-up ring.	36
400A Standard Heel w/ Back-up					
Rod Seals .185 - 60+ Piston Seals .297 - 60+	1/16 to 1/4**	AS 4716 Industrial MIL-G-5514	Low Moderate	Best suited for dynamic rod and piston seals when pressure exceeds 6,000 PSI and excessive hardware extrusion gaps with high temperatures are present. A high modulus material like Meldin® 5301 is recommended for the back-up ring to reduce the gap and prevent seal extrusion.	36
400A Flanged Heel					
Rod Seals .185 - 60+ Piston Seals .297 - 60+	1/16 to 1/4**	AS 4716 Industrial MIL-G-5514	Low Moderate	Designed for rotary shaft applications at less than 500 SFPM. The flange is an anti-rotation device when locked into the mating hardware. Also used as a cryogenic seal in applications such as quick disconnect couplings used in liquid oxygen and nitrogen. The flange prevents shrinkage.	36
103A Series					
Rod Seals .076 - 60+ Piston Seals .190 - 60+	1/16 to 1/2**	AS 4716 Industrial MIL-G-5514	Moderate High	Generally used for static applications when positive sealing is most critical. Best suited for use in sealing light gases and vacuum. Can be used in slow dynamic situations when friction is less of a concern. Also used as a cryogenic seal in applications such as quick disconnect couplings used in liquid oxygen and nitrogen.	37
Spring Ring II Series					
Rod Seals .108 - .873 Piston Seals .221 - 1.116	1/16 to 1/8	-005 to -212 AS 4716 Industrial MIL-G-5514	Low Moderate	Similar in design to the 400A listed above and intended for high volume, less critical applications. Available in fixed cross section sizes for diameters less than 1". Only available with 301 or 316 stainless steel springs. Custom sizes are available with a nominal setup cost.	38
APS Series					
Rod Seals .032 - 16 Piston Seals .094 - 16	1/16 to 1/4 (1/32" available)	AS 4716 Industrial MIL-G-5514	Low Moderate	The near constant spring force Advanced Pitch Spring design is best suited for applications where consistent friction is important. Best when used for small diameters in rotary and reciprocating rod and piston applications at temps under 475°F (246°C). Optional spring loads available.	39
RP II Series					
Rod Seals .250 - 60 Piston Seals .427 - 60	3/32 to 1/4**	AS 4716 Industrial MIL-G-5514	Moderate	Flexible overlapped spring designed for use in static slow dynamic applications when excessive hardware tolerances exist. Spring design affords maximum spring deflection. Recommended for use in viscous applications, such as injection molding and liquid filling equipment.	40
RACO® 1100 Series					
.750 - 60+	3/32 to 1/4**	Industrial	High	High load spring designed for static internal and external pressure face seal applications. Excellent sealing in light gases, vacuum and cryogenics. Also used in slow dynamic face seal applications such as swivel joints and marine loading arms.	41

P: Poor F: Fair G: Good E: Excellent

*Optional. Consult factory or contact technical support.

**Special cross-sections seals up to 1" are available.

How to Order Our Standard Omniseal® Products

Radial Seal (MIL-G-5514 and Industrial Glands) and Face Seal

Seal Design

- 400A (see page 36)
- 103A (see page 37)
- Spring Ring II (see page 38)
- APS (see page 39)
- RP II (see page 40)
- RACO® 1100A (see page 41)

Seal Size

- Radial Seal (see page 47-51)
- Face Seal (Inside) (see page 52-54)
- Face Seal (Outside) (see page 55-57)

Jacket Material

(see pages 8-10)

Energizer Material

(see page 14)

Spring Load* (for APS Seal Type Only)

- L - Low
- M - Medium
- H - High

*Default Spring Load is Medium for Radial Seals and High for Face Seals

EXAMPLE: 230-210-A01-09

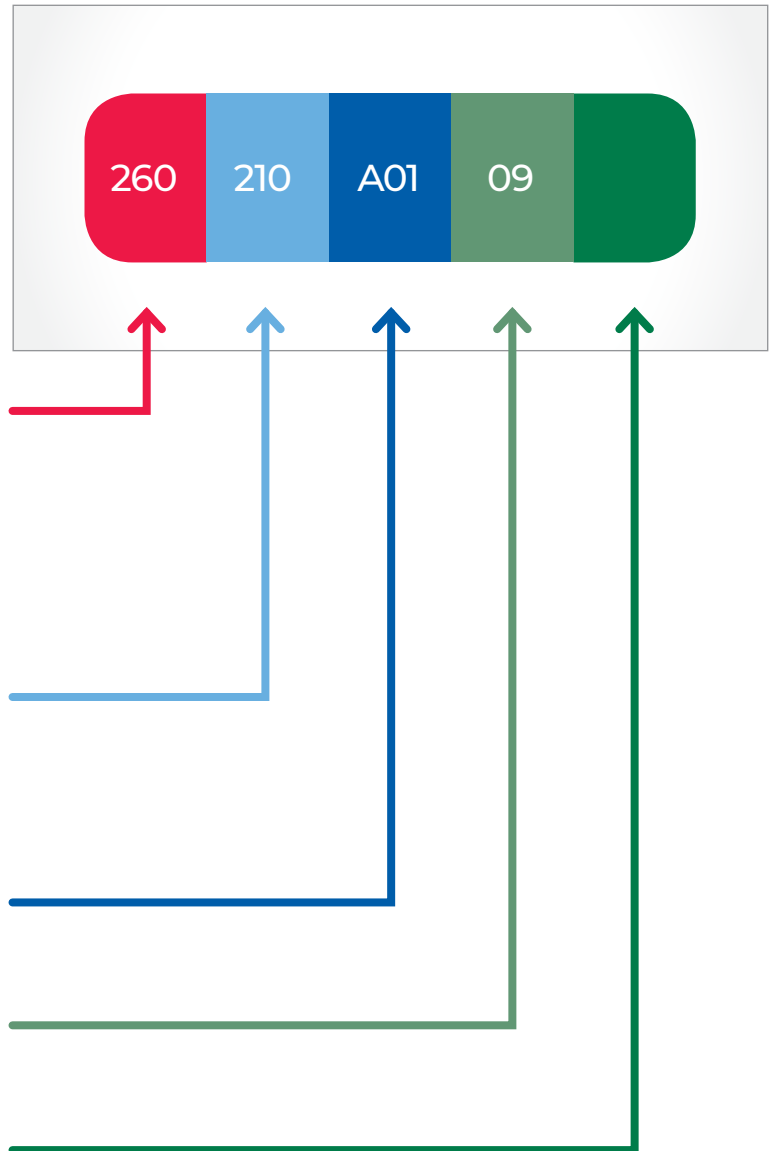

How to Order Our Standard Omniseal® Products

Radial Seal (AS4716 Glands)

EXAMPLE: 260-R-210-A01-09

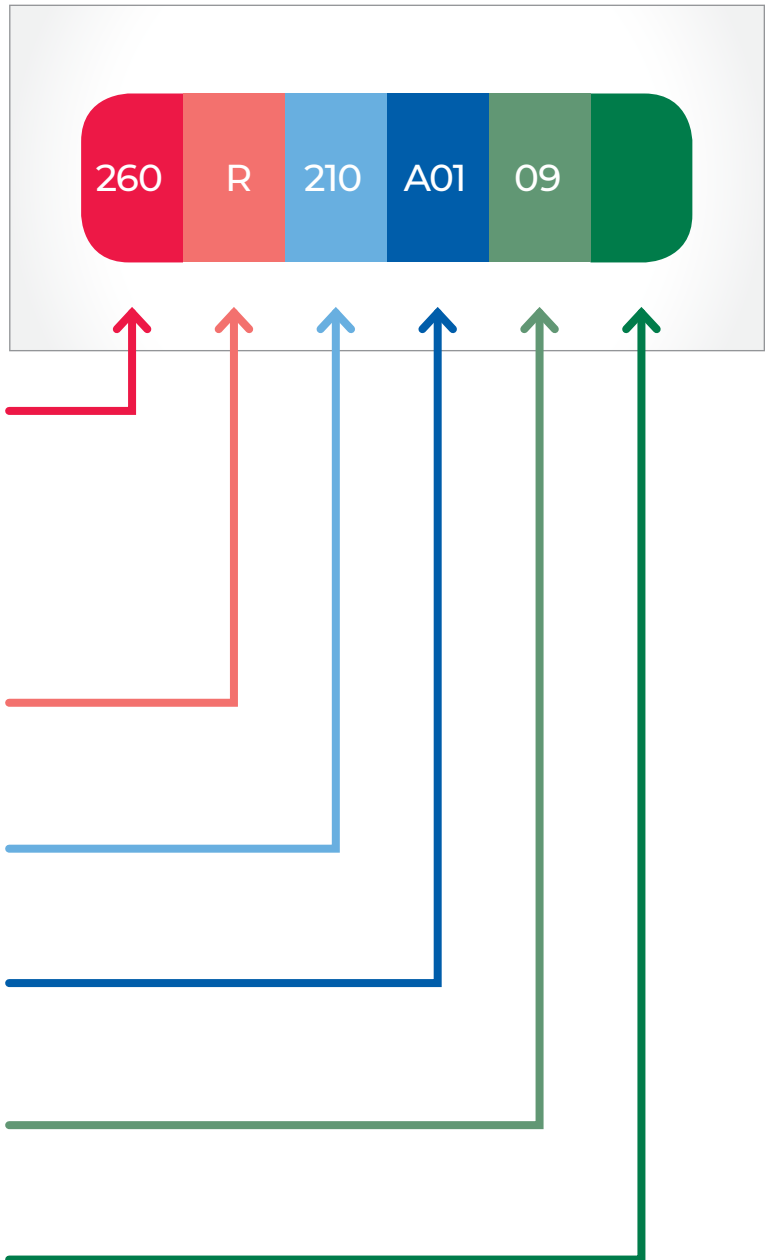

Seal Design

- 400A (see page 36)
- 103A (see page 37)
- Spring Ring II (see page 38)
- APS (see page 39)
- RP II (see page 40)
- RACO® 1100A (see page 41)

Rod or Piston Seal

- R - Rod
- P - Piston

Seal Size

(see pages 44-46)

Jacket Material

(see pages 8-10)

Energizer Material

(see page 14)

Spring Load* (for APS Seal Type Only)

- L - Low
- M - Medium
- H - High

*Default Spring Load is Medium



Omniseal® 400A

Features







- Cantilevered finger spring design
- Low spring loading
- Standard spring force can be tailored to higher and lower loads
- Available in standard heel, extended heel and flanged heel designs
- Available to fit in all aerospace, military and industrial gland sizes
- Available in larger cross sections up to 3/4"

Benefits

- Provides more dynamic run-out
- Accommodates wider gland tolerances
- Provides very low friction
- High- and low-pressure sealing
- Excellent in rotary speeds from slow to moderate
- Low hardware clamping force required
- High-temperature sealing
- Excellent in rotary face seal applications

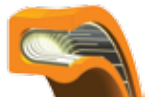

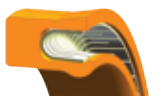
RADIAL SEAL

	Standard Lip	Skived I.D. Lip	Skived O.D. Lip
Standard Heel G Width			
Seal Design	AS 260 MIL 220 IND 240	AS 261 MIL 221 IND 241	AS 262 MIL 222 IND 242
Extended Heel G₁ Width			
Seal Design	AS 263 MIL 223 IND 243	AS 264 MIL 224 IND 244	AS 265 MIL 225 IND 245
Flanged Heel G₁ Width			
Seal Design	AS 266 MIL 226 IND 246	AS 267 MIL 227 IND 247	

NOTE: Complete rod and piston radial seal gland dimensional data for AS4716, MIL-G-5514 and industrial glands 1/16" – 1/4" cross sections available on pages 44 through 57.

FACE SEAL

	Inside Face Seal (Internally Pressurized)	Outside Face Seal (Externally Pressurized)
		
Seal Design	228	229

NOTE: Complete face seal dimensional data for 1/16" – 1/4" cross sections available on pages 44 through 57.

Omniseal® 103A



RADIAL SEAL

	Standard Lip	Skived I.D. Lip	Skived O.D. Lip
Standard Heel G Width			
Seal Design	AS 160 MIL 230 IND 250	AS 161 MIL 231 IND 251	AS 162 MIL 232 IND 252
Extended Heel G₁ Width			
Seal Design	AS 163 MIL 233 IND 253	AS 164 MIL 234 IND 254	AS 165 MIL 235 IND 255
Flanged Heel G₁ Width			
Seal Design	AS 166 MIL 236 IND 256	AS 167 MIL 237 IND 257	

NOTE: Complete rod and piston radial seal gland dimensional data for AS4716, MIL-G-5514 and industrial glands 1/16" – 1/4" cross sections available on pages 44 through 57.

FACE SEAL

	Inside Face Seal (Internally Pressurized)	Outside Face Seal (Externally Pressurized)
Seal Design	238	239

NOTE: Complete face seal dimensional data for 1/16" – 1/4" cross sections available on pages 44 through 57.

Features

- Helical wound flat spring design
- High spring load with small deflection range
- Standard spring force can be tailored to higher and lower loads
- Available in standard heel, extended heel and flanged heel designs
- Available to fit in all aerospace, military and industrial gland sizes

Benefits

- Excellent for static, intermittent and slower dynamic applications
- Better sealing of light liquids and gases
- Excellent in static face sealing
- Excellent for applications that require extremely low leak rate
- Easily installed in closed grooves





Omniseal® Spring Ring II (SR II)

Features









- Cantilevered finger spring design
- No weld line in the spring
- Special type of Omniseal® 400A
- Available in select sizes only (1/8" to 7/8" I.D. and nominal cross section of 1/16", 3/32" and 1/8")

Benefits

- Provides more dynamic run-out
- Accommodates wider gland tolerances
- Provides low friction
- High- and low-pressure sealing
- Low hardware clamping force



RADIAL SEAL

	Standard Lip	Skived I.D. Lip	Skived O.D. Lip
Standard Heel G Width			
Seal Design	AS 060 MIL 010 IND 080	AS 061 MIL 011 IND 081	AS 062 MIL 012 IND 082
Extended Heel G₁ Width			
Seal Design	AS 063 MIL 013 IND 083	AS 064 MIL 014 IND 084	AS 065 MIL 015 IND 085
Flanged Heel G₁ Width			
Seal Design	AS 066 MIL 016 IND 086	AS 067 MIL 017 IND 087	

NOTE: Complete rod and piston radial seal gland dimensional data for AS4716, MIL-G-5514 and industrial glands 1/16" – 1/4" cross sections available on pages 44 through 57.

I.D. FLANGED HEEL

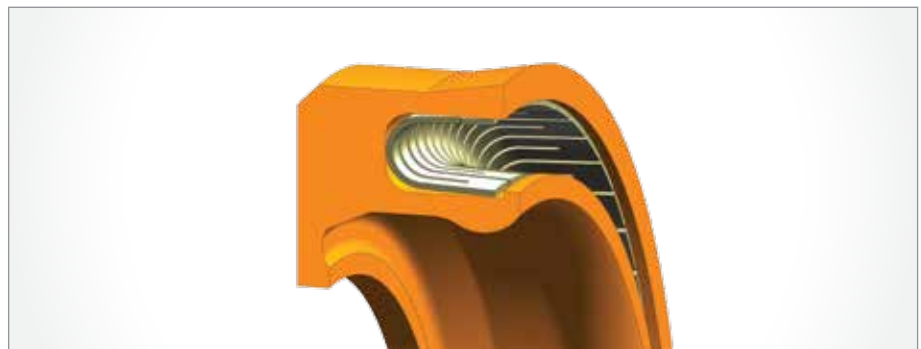

Special Designs

The Spring Ring II can be modified to meet particular requirements. The example shown to the right with flange on the I.D. is used to prevent seal rotation on a piston application. This design can also be applied to Omniseal® APS, 400A, 103A and RP II jacket designs.



RADIAL SEAL

	Standard Lip	Skived I.D. Lip	Skived O.D. Lip
Standard Heel G Width			
Seal Design	AS 760 MIL 730 IND 750	AS 761 MIL 731 IND 751	AS 762 MIL 732 IND 752
Extended Heel G₁ Width			
Seal Design	AS 763 MIL 733 IND 753	AS 764 MIL 734 IND 754	AS 765 MIL 735 IND 755
Flanged Heel G₁ Width			
Seal Design	AS 766 MIL 736 IND 756	AS 767 MIL 737 IND 757	

NOTE: Complete rod and piston radial seal gland dimensional data for AS4716, MIL-G-5514 and industrial glands 1/16" – 1/4" cross sections available on pages 44 through 57.

FACE SEAL

	Inside Face Seal (Internally Pressurized)	Outside Face Seal (Externally Pressurized)
Seal Design	738	739

NOTE: Complete face seal dimensional data for 1/16" – 1/4" cross sections available on pages 44 through 57.

Features

- Coiled wire spring design
- Very low spring loading
- Very low stress on spring
- Constant spring loading over a wide range of deflection
- The standard spring load can be increased or decreased

Benefits

- Permits large wear allowance in the seal jacket
- Great in small diameter and smaller cross section sealing housing
- Can be installed in closed glands without damaging the seal
- Very good for applications that require low friction in dynamic conditions





Omniseal® RP II

Features



- Wrapped and formed ribbon spring
- Very high spring loading
- Most resilient spring
- Only available in radial-type seal design
- The standard spring load can be increased or decreased

Benefits

- Rugged, durable seal ideal for the most severe mechanical conditions where other seals fail





RADIAL SEAL

	Standard Lip
Standard Heel G Width	
Seal Design	AS 360 MIL 320 IND 340
Extended Heel G₁ Width	
Seal Design	AS 363 MIL 323 IND 343
Flanged Heel G₁ Width	
Seal Design	AS 366 MIL 326 IND 346

NOTE: Complete rod and piston radial seal gland dimensional data for AS4716, MIL-G-5514 and industrial glands 1/16" – 1/4" cross sections available on pages 44 through 57.

Omniseal® RACO® 1100A

FACE SEAL

	Inside Face Seal (Internally Pressurized)	Outside Face Seal (Externally Pressurized)
Standard Heel G Width		
Seal Design	348	349

NOTE: Complete face seal dimensional data for 1/16" – 1/4" cross sections available on pages 44 through 57.

Features

- Heavy duty, high load RACO® spring design
- Available in large cross sections and diameters

Benefits

- Continuous spring contact along the entire sealing lip
- Excellent in extreme static sealing conditions, involving cryogenic fluids, ultra high vacuum and light gases
- Withstands high torque and clamping force
- Resists permanent set
- Excellent in marine loading arms



Our Omniseal® Back-up Rings

PISTON SEAL INSTALLATION WITH DUAL BACK-UP RINGS

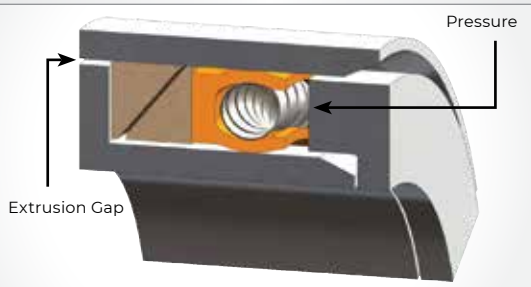

ROD SEAL INSTALLATION WITH DUAL BACK-UP RINGS

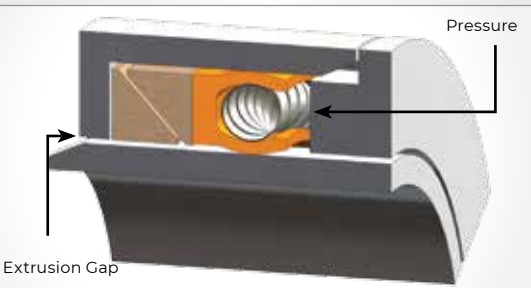

HIGH MODULUS ANTI-EXTRUSION/WEAR RING

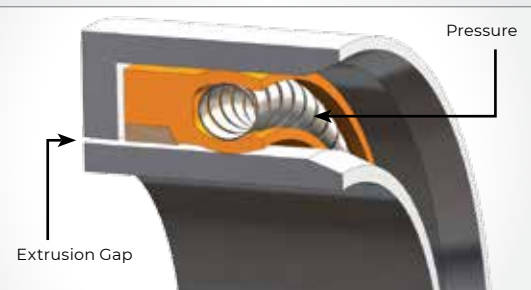

L-SHAPED BACK-UP RING



Omniseal® back-up rings help to prevent seal extrusion at high temperature and pressure. Extrusion is a function of:

- The size of extrusion gap
- Temperature
- Pressure
- Surface speed (in reciprocating applications)

When under pressure, PTFE material in the seal tends to flow into the extrusion gap. Dynamic reciprocating movements increase extrusion. Under static conditions and when pressure, temperature and the extrusion gap are below certain limits, extrusion will stop as soon as the pressure created by friction in the extrusion gap equals the system pressure. Cyclic conditions can cause extrusion to continue and result in premature failure of the seal.

Our back-up rings are specially designed to work in high-pressure and high-temperature applications with the radial Omniseal® seals. They should also be considered for use in high-pressure and high-speed applications.

Rectangular Back-up Ring

In most applications with lower pressure and temperatures below 475°F (246°C), a rectangular back-up ring will secure the seal from extrusion. These back-up rings are machined to fit securely in the radial groove width. The selected material should be a compound with a higher extrusion resistance than the seal material (see page 43).

Triangular Back-up Ring

In applications where high temperature precedes high pressure, a triangular back-up ring is recommended (see page 43).

Double Triangular Back-up Ring

For extreme high pressure and temperature combinations, a set of two triangular back-up rings is recommended. This configuration is often used when the radial groove dimension changes as a result of system pressure (see Piston Seal and Rod Seal figures).

Special Design Back-up Rings

The metallic anti-extrusion/wear ring is a special type of back-up ring used in extremely high pressure applications. The L-shaped back-up ring is used to prevent extrusion in extreme high-pressure and high-temperature combinations. It is capable of securing PTFE seals up to 575°F (302°C) and pressures up to 2,900 PSI (20 MPa), with very large extrusion gaps (see High Modulus and L-Shaped figures).

How to Order Our Back-Up Ring Products

EXAMPLE: 035-001-22

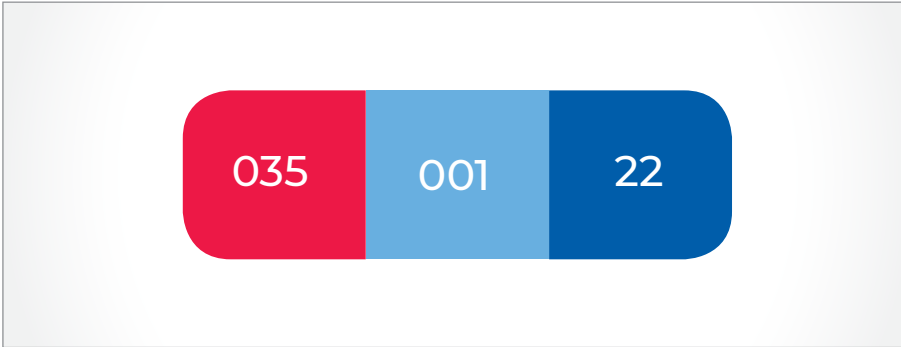

Ring/Gland Type

(see below)

Dash No.

Shaft/Bore size (see pages 44-57)

Back-up rings are recommended for use with Standard Heel Omniseal® seals when the gland width = G_2



Material Code

(see pages 8-10)

Back-up Ring Materials

The back-up ring should consist of a harder material than the seal material. A high filled PTFE compound, or a high modulus plastic such as Meldin® 5301 is recommended. Polymeric materials such as filled PTFE, PEEK and reinforced PEEK prevent the softer seal material from extruding in the gap between adjacent hardware.

BACK-UP RING/GLAND TYPE

Gland	Back-up Ring		
			
MIL-G-5514	035	036	037
Industrial	055	056	057
AS4716	175	176	177



Radial Seal Gland Dimensions AS4716

1/16" CROSS SECTION

For Dash No. 004 - 009: G = 0.098/0.103, C₁ = 0.154/0.164, C₂ = 0.210/0.220
For Dash No. 010 - 028: G = 0.094/0.099, C₁ = 0.150/0.160, C₂ = 0.207/0.217

Dash No.	Pistol Seal		Rod Seal		APS	Spring Ring II	400A	103A	RP II	Back-up Rings
	A Cylinder Bore Dia.	F Piston Groove Dia.	E Groove Dia.	B Rod Dia.						
	Tol. +0.001 -0.000	Tol. +0.000 -0.001	Tol. +0.001 -0.000	Tol. +0.000 -0.001						
004	0.190	0.076	0.190	0.076
005	0.221	0.115	0.217	0.108
006	0.235	0.129	0.232	0.123
007	0.266	0.158	0.264	0.154
008	0.297	0.189	0.294	0.185
009	0.329	0.220	0.327	0.217
010	0.360	0.250	0.359	0.248
011	0.422	0.312	0.421	0.310
012	0.485	0.375	0.484	0.373
	Tol. +0.002 -0.000	Tol. +0.000 -0.002	Tol. +0.002 -0.000	Tol. +0.000 -0.002						
013	0.550	0.441	0.545	0.435
014	0.613	0.504	0.608	0.498
015	0.675	0.566	0.670	0.560
016	0.738	0.629	0.733	0.623
017	0.800	0.691	0.795	0.685
018	0.863	0.753	0.858	0.748
019	0.925	0.815	0.920	0.810
020	0.991	0.881	0.983	0.873
021	1.053	0.943	1.045	0.935
022	1.116	1.006	1.108	0.998
023	1.178	1.068	1.170	1.060
024	1.241	1.131	1.233	1.123
025	1.303	1.193	1.295	1.185
026	1.366	1.256	1.358	1.248
027	1.428	1.318	1.420	1.310
028	1.491	1.381	1.483	1.373

· Indicates availability

NOTE: Aerospace Standard AS4716 gland dimensions are designed for elastomeric seal glands for static and dynamic applications. They are closed one-piece grooves that will not provide the necessary access for most radial Omniseal® seals. The information on these pages conforms to the specification for dimensioning purposes only. Gland design information for Omniseal® seals can be found on pages 20 and 21.

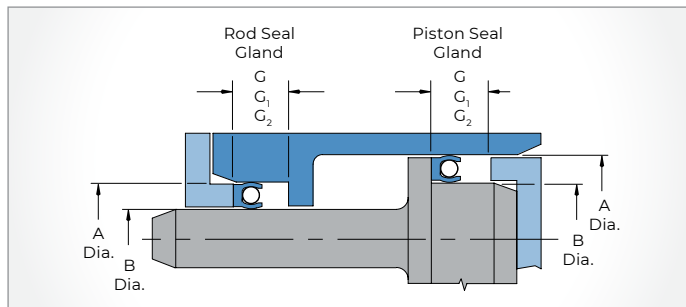

G: Gland width for standard heel Omniseal®

G₁: Gland width for extended heel and flanged heel Omniseal®

G₂: Gland width for standard heel Omniseal® plus back-up ring

3/32" CROSS SECTION

G = 0.141/0.151, C₁ = 0.183/0.193, C₂ = 0.245/0.255

Dash No.	Pistol Seal		Rod Seal		APS	Spring Ring II	400A	103A	RP II	Back-up Rings
	A Cylinder Bore Dia.	F Piston Groove Dia.	E Groove Dia.	B Rod Dia.						
	Tol. +0.002 -0.000	Tol. +0.000 -0.002	Tol. +0.002 -0.000	Tol. +0.000 -0.002						
110	0.550	0.379	0.546	0.373
111	0.613	0.441	0.609	0.435
112	0.675	0.502	0.672	0.498
113	0.738	0.565	0.734	0.560
114	0.800	0.627	0.797	0.623
115	0.863	0.689	0.859	0.685
116	0.925	0.751	0.923	0.748
117	0.991	0.817	0.985	0.810
118	1.053	0.879	1.048	0.873
119	1.116	0.942	1.110	0.935
120	1.178	1.003	1.173	0.998
121	1.241	1.066	1.235	1.060
122	1.303	1.128	1.298	1.123
123	1.366	1.191	1.360	1.185
124	1.428	1.253	1.423	1.248
125	1.491	1.316	1.485	1.310
126	1.553	1.378	1.548	1.373
127	1.616	1.441	1.610	1.435
128	1.678	1.503	1.673	1.498
129	1.741	1.566	1.735	1.560
130	1.805	1.631	1.798	1.623
131	1.867	1.693	1.860	1.685
132	1.930	1.756	1.923	1.748
133	1.992	1.818	1.984	1.810
134	2.055	1.881	2.047	1.873
135	2.118	1.944	2.110	1.936
136	2.180	2.006	2.172	1.998
137	2.243	2.069	2.235	2.061
138	2.305	2.131	2.297	2.123
139	2.368	2.194	2.360	2.186
140	2.430	2.256	2.422	2.248
141	2.493	2.319	2.485	2.311
142	2.555	2.381	2.547	2.373
143	2.618	2.444	2.610	2.436
144	2.680	2.506	2.672	2.498
145	2.743	2.569	2.735	2.561
146	2.805	2.631	2.797	2.623
147	2.868	2.694	2.860	2.686
148	2.930	2.756	2.922	2.748
149	2.993	2.819	2.985	2.811

Radial Seal Gland Dimensions AS4716



Omniseal Solutions
SAINT-GOBAIN

1/8" CROSS SECTION

G = 0.188/0.198, G₁ = 0.235/0.245, G₂ = 0.304/0.314

Dash No.	Pistol Seal		Rod Seal		APS	Spring Ring II	400A	103A	RP II	Back-up Rings
	A Cylinder Bore Dia.	F Piston Groove Dia.	E Groove Dia.	B Rod Dia.						
	Tol. +0.002 -0.000	Tol. +0.000 -0.002	Tol. +0.002 -0.000	Tol. +0.000 -0.002						
210	0.991	0.750	0.989	0.748
211	1.053	0.812	1.051	0.810
212	1.116	0.874	1.115	0.873
213	1.178	0.936	1.177	0.935
214	1.241	0.999	1.240	0.998
215	1.303	1.061	1.302	1.060
216	1.366	1.124	1.365	1.123
217	1.428	1.186	1.427	1.185
218	1.491	1.249	1.490	1.248
219	1.553	1.311	1.552	1.310
220	1.616	1.374	1.615	1.373
221	1.678	1.436	1.677	1.435
222	1.741	1.499	1.740	1.498
223	1.867	1.625	1.865	1.623
224	1.992	1.750	1.990	1.748
225	2.118	1.876	2.115	1.873
226	2.243	2.001	2.240	1.998
227	2.368	2.126	2.365	2.123
228	2.493	2.251	2.490	2.248
229	2.618	2.376	2.615	2.373
230	2.743	2.501	2.740	2.498
231	2.868	2.626	2.865	2.623
232	2.993	2.751	2.990	2.748
233	3.118	2.876	3.115	2.873
234	3.243	3.001	3.239	2.997
235	3.368	3.126	3.364	3.122
236	3.493	3.251	3.489	3.247
237	3.618	3.376	3.614	3.372
238	3.743	3.501	3.739	3.497
239	3.868	3.626	3.864	3.622
240	3.993	3.751	3.989	3.747
241	4.118	3.876	4.114	3.872
242	4.243	4.001	4.239	3.997
243	4.368	4.126	4.364	4.122
244	4.493	4.251	4.489	4.247
245	4.618	4.376	4.614	4.372
246	4.743	4.501	4.739	4.497
247	4.868	4.626	4.864	4.622

3/16" CROSS SECTION

G = 0.281/0.291, G₁ = 0.334/0.344, G₂ = 0.424/0.434

Dash No.	Pistol Seal		Rod Seal		APS	Spring Ring II	400A	103A	RP II	Back-up Rings
	A Cylinder Bore Dia.	F Piston Groove Dia.	E Groove Dia.	B Rod Dia.						
	Tol. +0.002 -0.000	Tol. +0.000 -0.002	Tol. +0.002 -0.000	Tol. +0.000 -0.002						
325	1.867	1.495	1.870	1.498
326	1.992	1.620	1.995	1.623
327	2.118	1.746	2.120	1.748
328	2.243	1.871	2.245	1.873
329	2.368	1.996	2.370	1.998
330	2.493	2.121	2.495	2.123
331	2.618	2.246	2.620	2.248
332	2.743	2.371	2.745	2.373
333	2.868	2.496	2.870	2.498
334	2.993	2.621	2.995	2.623
335	3.118	2.746	3.120	2.748
336	3.243	2.871	3.245	2.873
337	3.368	2.996	3.369	2.997
338	3.493	3.121	3.494	3.122
339	3.618	3.246	3.619	3.247
340	3.743	3.371	3.744	3.372
341	3.868	3.496	3.869	3.497
342	3.993	3.621	3.994	3.622
343	4.118	3.746	4.119	3.747
344	4.243	3.871	4.244	3.872
345	4.368	3.996	4.369	3.997
346	4.493	4.121	4.494	4.122
347	4.618	4.246	4.619	4.247
348	4.743	4.371	4.744	4.372
349	4.868	4.496	4.869	4.497



Radial Seal Gland Dimensions AS4716

1/4" CROSS SECTION

G = 0.375/0.385, G₁ = 0.475/0.485, G₂ = 0.579/0.589

Dash No.	Pistol Seal		Rod Seal		APS	Spring Ring II	400A	103A	RP II	Back-up Rings
	A Cylinder Bore Dia.	F Pistol Groove Dia.	E Groove Dia.	B Rod Dia.						
	Tol. +0.003 -0.000	Tol. +0.000 -0.003	Tol. +0.003 -0.000	Tol. +0.000 -0.003						
425	4.974	4.497	4.974	4.497
426	5.099	4.622	5.099	4.622
427	5.224	4.747	5.224	4.747
428	5.349	4.872	5.349	4.872
429	5.474	4.997	5.474	4.997
430	5.599	5.122	5.599	5.122
431	5.724	5.247	5.724	5.247
432	5.849	5.372	5.849	5.372
433	5.974	5.497	5.974	5.497
434	6.099	5.622	6.099	5.622
435	6.224	5.747	6.224	5.747
436	6.349	5.872	6.349	5.872
437	6.474	5.997	6.474	5.997
438	6.724	6.247	6.724	6.247
439	6.974	6.497	6.974	6.497
440	7.224	6.747	7.224	6.747
441	7.474	6.997	7.474	6.997
442	7.724	7.247	7.724	7.247
443	7.974	7.497	7.974	7.497
444	8.224	7.747	8.224	7.747
445	8.474	7.997	8.474	7.997
446	8.974	8.497	8.974	8.497
	Tol. +0.004 -0.000	Tol. +0.000 -0.003	Tol. +0.004 -0.000	Tol. +0.000 -0.003						
447	9.474	8.997	9.474	8.997
448	9.974	9.497	9.974	9.497
449	10.474	9.997	10.474	9.997
450	10.974	10.497	10.974	10.497
451	11.474	10.997	11.474	10.997
452	11.974	11.497	11.974	11.497
453	12.474	11.997	12.474	11.997
454	12.974	12.497	12.974	12.497
455	13.474	12.997	13.474	12.997
456	13.974	13.497	13.974	13.497
457	14.474	13.997	14.474	13.997
458	14.974	14.497	14.974	14.497
459	15.474	14.997	15.474	14.997
460	15.974	15.497	15.974	15.497

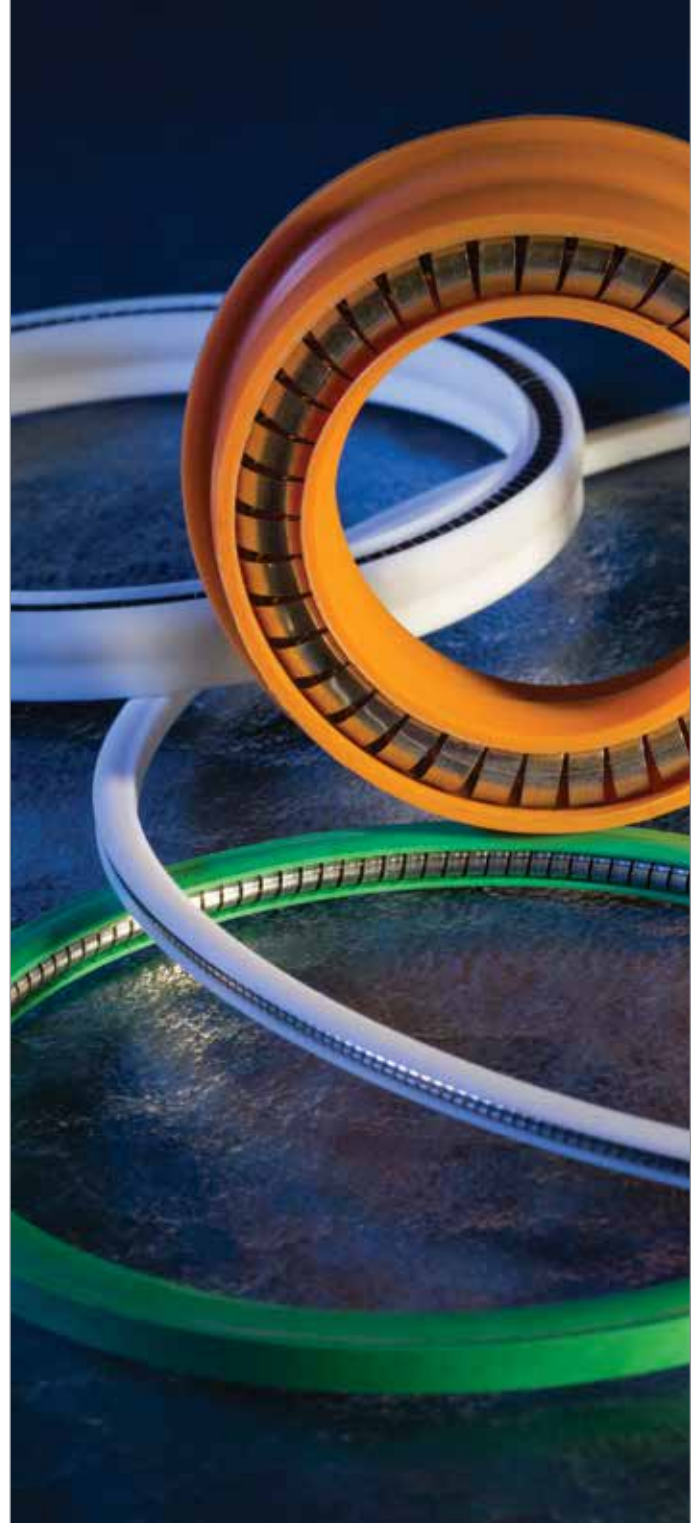

Radial Seal Gland Dimensions MIL-G-5514 and Industrial

1/16" CROSS SECTION

G = 0.094/0.104, G₁ = 0.149/0.159, G₂ = 0.207/0.217

Dash No.	MIL-G-5514		APS	Spring Ring II	400A	103A	RP II	Back-up Rings	Industrial	
	A Dia.	B Dia.							A Dia.	B Dia.
	Tol. +0.001 -0.000	Tol. +0.000 -0.001							Tol. +0.001 -0.000	Tol. +0.000 -0.001
001	0.095	0.033								
002	0.128	0.048							Refer to Factory for Part Numbers	
003	0.159	0.063								
004	0.190	0.076	.						0.203	0.078
005	0.221	0.108	.	.					0.234	0.109
006	0.235	0.123	.	.	.				0.250	0.125
007	0.266	0.154	.	.	.				0.281	0.156
008	0.297	0.185	.	.	.				0.312	0.187
009	0.329	0.217	.	.	.				0.343	0.218
010	0.360	0.248	.	.	.				0.375	0.250
011	0.422	0.310	.	.	.				0.437	0.312
012	0.485	0.373	.	.	.				0.500	0.375
	Tol. +0.002 -0.000	Tol. +0.000 -0.002							Tol. +0.002 -0.000	Tol. +0.000 -0.002
013	0.550	0.438	.	.	.				0.562	0.437
014	0.613	0.501	.	.	.				0.625	0.500
015	0.675	0.563	.	.	.				0.687	0.562
016	0.738	0.626	.	.	.				0.750	0.625
017	0.800	0.688	.	.	.				0.812	0.687
018	0.863	0.751	.	.	.				0.875	0.750
019	0.925	0.813	.	.	.				0.937	0.812
020	0.993	0.881	.	.	.				1.000	0.875
021	1.055	0.943	.	.	.				1.062	0.937
022	1.118	1.006	.	.	.				1.125	1.000
023	1.180	1.068	.	.	.				1.187	1.062
024	1.243	1.131	.	.	.				1.250	1.125
025	1.305	1.193	.	.	.				1.312	1.187
026	1.368	1.256	.	.	.				1.375	1.250
027	1.430	1.318	.	.	.				1.437	1.312
028	1.493	1.381	.	.	.				1.500	1.375
029	1.617	1.505	.	.	.				1.625	1.500
030	1.739	1.627	.	.	.				1.750	1.625
031	1.864	1.752	.	.	.				1.875	1.750
032	1.989	1.877	.	.	.				2.000	1.875
033	2.114	2.002	.	.	.				2.125	2.000
034	2.239	2.127	.	.	.				2.250	2.125
035	2.364	2.252	.	.	.				2.375	2.250
036	2.489	2.377	.	.	.				2.500	2.375
037	2.614	2.502	.	.	.				2.625	2.500

G = 0.094/0.104, G₁ = 0.149/0.159, G₂ = 0.207/0.217

Dash No.	MIL-G-5514		APS	Spring Ring II	400A	103A	RP II	Back-up Rings	Industrial	
	A Dia.	B Dia.							A Dia.	B Dia.
	Tol. +0.002 -0.000	Tol. +0.000 -0.002							Tol. +0.002 -0.000	Tol. +0.000 -0.002
038	2.739	2.627	.						2.750	2.625
039	2.864	2.752	.						2.875	2.750
040	2.987	2.875	.						3.000	2.875
041	3.112	3.000	.						3.125	3.000
042	3.362	3.250	.						3.375	3.250
043	3.612	3.500	.						3.625	3.500
044	3.862	3.750	.						3.875	3.750
045	4.112	4.000	.						4.125	4.000

• Indicates availability

NOTE:

1. If space permits, use the larger cross sections listed in these tables.
2. Diameters between those listed and diameters larger than those listed are available on request.
3. In-between cross sections and larger cross sections are available.
4. Metric sizes are also available.

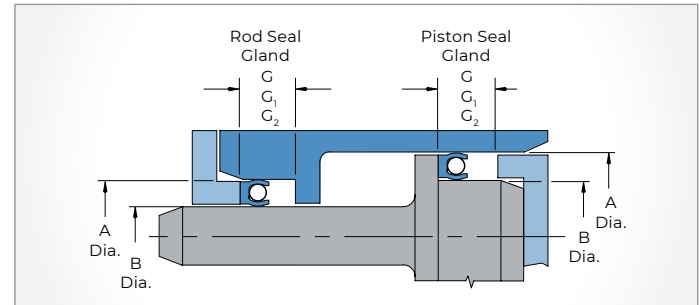

G: Gland width for standard heel OmniSeal®

G₁: Gland width for extended heel and flanged heel OmniSeal®

G₂: Gland width for standard heel OmniSeal® plus back-up ring

Radial Seal Gland Dimensions MIL-G-5514 and Industrial

3/32" CROSS SECTION

G = 0.141/0.151, G₁ = 0.183/0.193, G₂ = 0.245/0.255

Dash No.	MIL-G-5514		APS	Spring Ring II	400A	103A	RP II	Back-up Rings	Industrial	
	A Dia.	B Dia.							A Dia.	B Dia.
	Tol. +0.002 -0.000	Tol. +0.000 -0.002							Tol. +0.002 -0.000	Tol. +0.000 -0.002
106	0.302	0.124	0.312	0.125	
107	0.364	0.186	0.375	0.187	
108	0.427	0.249	0.437	0.250	
109	0.489	0.311	0.500	0.312	
110	0.551	0.373	0.562	0.375	
111	0.613	0.435	0.625	0.437	
112	0.676	0.498	0.687	0.500	
113	0.738	0.560	0.750	0.562	
114	0.801	0.623	0.812	0.625	
115	0.863	0.685	0.875	0.687	
116	0.926	0.748	0.937	0.750	
117	0.993	0.815	1.000	0.812	
118	1.056	0.878	1.062	0.875	
119	1.118	0.940	1.125	0.937	
120	1.181	1.003	1.187	1.000	
121	1.243	1.065	1.250	1.062	
122	1.306	1.128	1.312	1.125	
123	1.368	1.190	1.375	1.187	
124	1.431	1.253	1.437	1.250	
125	1.493	1.315	1.500	1.312	
126	1.558	1.380	1.562	1.375	
127	1.620	1.442	1.625	1.437	
128	1.683	1.505	1.687	1.500	
129	1.742	1.564	1.750	1.562	
130	1.805	1.627	1.812	1.625	
131	1.867	1.689	1.875	1.687	
132	1.930	1.752	1.937	1.750	
133	1.992	1.814	2.000	1.812	
134	2.055	1.877	2.062	1.875	
135	2.118	1.940	2.125	1.937	
136	2.180	2.002	2.187	2.000	
137	2.243	2.065	2.250	2.062	
138	2.305	2.127	2.312	2.125	
139	2.368	2.190	2.375	2.187	
140	2.430	2.252	2.437	2.250	
141	2.493	2.315	2.500	2.312	
142	2.555	2.377	2.562	2.375	
143	2.618	2.440	2.625	2.437	
144	2.680	2.502	2.687	2.500	
145	2.743	2.565	2.750	2.562	

G = 0.141/0.151, G₁ = 0.183/0.193, G₂ = 0.245/0.255

Dash No.	MIL-G-5514		APS	Spring Ring II	400A	103A	RP II	Back-up Rings	Industrial	
	A Dia.	B Dia.							A Dia.	B Dia.
	Tol. +0.002 -0.000	Tol. +0.000 -0.002							Tol. +0.002 -0.000	Tol. +0.000 -0.002
146	2.805	2.627	2.812	2.625	
147	2.868	2.690	2.875	2.687	
148	2.930	2.752	2.937	2.750	
149	2.993	2.815	3.000	2.812	
150	3.053	2.875	3.062	2.875	
151	3.178	3.000	3.187	3.000	
152	3.428	3.250	3.437	3.250	
153	3.678	3.500	3.687	3.500	
154	3.928	3.750	3.937	3.750	
155	4.178	4.000	4.187	4.000	
156	4.428	4.250	4.437	4.250	
157	4.678	4.500	4.687	4.500	
158	4.928	4.750	4.937	4.750	
159	5.178	5.000	5.187	5.000	
160	5.428	5.250	5.437	5.250	
161	5.678	5.500	5.687	5.500	
162	5.928	5.750	5.937	5.750	
163	6.178	6.000	6.187	6.000	

Radial Seal Gland Dimensions MIL-G-5514 and Industrial

1/8" CROSS SECTION

G = 0.188/0.198, G₁ = 0.234/0.245, G₂ = 0.304/0.314

Dash No.	MIL-G-5514		APS	Spring Ring II	400A	103A	RP II	Back-up Rings	Industrial	
	A Dia.	B Dia.							A Dia.	B Dia.
	Tol. +0.002 -0.000	Tol. +0.000 -0.002							Tol. +0.002 -0.000	Tol. +0.000 -0.002
202	0.491	0.249	0.500	0.250	
203	0.553	0.311	0.562	0.312	
204	0.615	0.373	0.625	0.375	
205	0.677	0.435	0.687	0.437	
206	0.740	0.498	0.750	0.500	
207	0.802	0.560	0.812	0.562	
208	0.865	0.623	0.875	0.625	
209	0.927	0.685	0.937	0.687	
210	0.991	0.748	1.000	0.750	
211	1.053	0.810	1.062	0.812	
212	1.116	0.873	1.125	0.875	
213	1.178	0.935	1.187	0.937	
214	1.241	0.998	1.250	1.000	
215	1.303	1.060	1.312	1.062	
216	1.366	1.123	1.375	1.125	
217	1.428	1.185	1.437	1.187	
218	1.491	1.248	1.500	1.250	
219	1.553	1.310	1.562	1.312	
220	1.616	1.373	1.625	1.375	
221	1.678	1.435	1.687	1.437	
222	1.741	1.498	1.750	1.500	
223	1.868	1.625	1.875	1.625	
224	1.993	1.750	2.000	1.750	
225	2.118	1.875	2.125	1.875	
226	2.243	2.000	2.250	2.000	
227	2.368	2.125	2.375	2.125	
228	2.493	2.250	2.500	2.250	
229	2.618	2.375	2.625	2.375	
230	2.743	2.500	2.750	2.500	
231	2.868	2.625	2.875	2.625	
232	2.993	2.750	3.000	2.750	
233	3.118	2.875	3.125	2.875	
234	3.243	3.000	3.250	3.000	
235	3.368	3.125	3.375	3.125	
236	3.493	3.250	3.500	3.250	
237	3.618	3.375	3.625	3.375	
238	3.743	3.500	3.750	3.500	
239	3.868	3.625	3.875	3.625	
240	3.993	3.750	4.000	3.750	
241	4.118	3.875	4.125	3.875	

G = 0.188/0.198, G₁ = 0.234/0.245, G₂ = 0.304/0.314

Dash No.	MIL-G-5514		APS	Spring Ring II	400A	103A	RP II	Back-up Rings	Industrial	
	A Dia.	B Dia.							A Dia.	B Dia.
	Tol. +0.002 -0.000	Tol. +0.000 -0.002							Tol. +0.002 -0.000	Tol. +0.000 -0.002
242	4.243	4.000	4.250	4.000	
243	4.368	4.125	4.375	4.125	
244	4.493	4.250	4.500	4.250	
245	4.618	4.375	4.625	4.375	
246	4.743	4.500	4.750	4.500	
247	4.868	4.625	4.875	4.625	
248	4.992	4.750	5.000	4.750	
249	5.117	4.875	5.125	4.875	
250	5.242	5.000	5.250	5.000	
251	5.367	5.125	5.375	5.125	
252	5.492	5.250	5.500	5.250	
253	5.617	5.375	5.625	5.375	
254	5.742	5.500	5.750	5.500	
255	5.867	5.625	5.875	5.625	
256	5.992	5.750	6.000	5.750	
257	6.117	5.875	6.125	5.875	
258	6.242	6.000	6.250	6.000	
259	6.492	6.250	6.500	6.250	
260	6.742	6.500	6.750	6.500	
261	6.992	6.750	7.000	6.750	
262	7.242	7.000	7.250	7.000	
263	7.492	7.250	7.500	7.250	
264	7.742	7.500	7.750	7.500	
265	7.992	7.750	8.000	7.750	
266	8.242	8.000	8.250	8.000	
267	8.492	8.250	8.500	8.250	
268	8.742	8.500	8.750	8.500	
269	8.992	8.750	9.000	8.750	
270	9.242	9.000	9.250	9.000	
271	9.492	9.250	9.500	9.250	
272	9.742	9.500	9.750	9.500	
273	9.992	9.750	10.000	9.750	
274	10.242	10.000	10.250	10.000	
275	10.742	10.500	10.750	10.500	
276	11.242	11.000	11.250	11.000	
277	11.742	11.500	11.750	11.500	
278	12.242	12.000	12.250	12.000	
279	12.742	12.500	12.750	12.500	
280	13.242	13.000	13.250	13.000	
281	13.742	13.500	13.750	13.500	

Radial Seal Gland Dimensions MIL-G-5514 and Industrial

3/16" CROSS SECTION

G = 0.281/0.291, G₁ = 0.334/0.344, G₂ = 0.424/0.434

Dash No.	MIL-G-5514		APS	Spring Ring II	400A	103A	RP II	Back-up Rings	Industrial	
	A Dia.	B Dia.							A Dia.	B Dia.
	Tol. +0.002 -0.000	Tol. +0.000 -0.002							Tol. +0.002 -0.000	Tol. +0.000 -0.002
313	0.870	0.498	0.875	0.500	
314	0.932	0.560	0.937	0.562	
315	0.995	0.623	1.000	0.625	
316	1.057	0.685	1.062	0.687	
317	1.120	0.748	1.125	0.750	
318	1.182	0.810	1.187	0.812	
319	1.245	0.873	1.250	0.875	
320	1.307	0.935	1.312	0.937	
321	1.370	0.998	1.375	1.000	
322	1.495	1.123	1.500	1.125	
323	1.620	1.248	1.625	1.250	
324	1.745	1.373	1.750	1.375	
325	1.870	1.498	1.875	1.500	
326	1.995	1.623	2.000	1.625	
327	2.120	1.748	2.125	1.750	
328	2.245	1.873	2.250	1.875	
329	2.370	1.998	2.375	2.000	
330	2.495	2.123	2.500	2.125	
331	2.620	2.248	2.625	2.250	
332	2.745	2.373	2.750	2.375	
333	2.870	2.498	2.875	2.500	
334	2.995	2.623	3.000	2.625	
335	3.120	2.748	3.125	2.750	
336	3.245	2.873	3.250	2.875	
337	3.369	2.997	3.375	3.000	
338	3.494	3.122	3.500	3.125	
339	3.619	3.247	3.625	3.250	
340	3.744	3.372	3.750	3.375	
341	3.869	3.497	3.875	3.500	
342	3.994	3.622	4.000	3.625	
343	4.119	3.747	4.125	3.750	
344	4.244	3.872	4.250	3.875	
345	4.369	3.997	4.375	4.000	
346	4.494	4.122	4.500	4.125	
347	4.619	4.247	4.625	4.250	
348	4.744	4.372	4.750	4.375	
349	4.869	4.497	4.875	4.500	
350	4.997	4.625	5.000	4.625	
351	5.122	4.750	5.125	4.750	
352	5.247	4.875	5.250	4.875	

G = 0.281/0.291, G₁ = 0.334/0.344, G₂ = 0.424/0.434

Dash No.	MIL-G-5514		APS	Spring Ring II	400A	103A	RP II	Back-up Rings	Industrial	
	A Dia.	B Dia.							A Dia.	B Dia.
	Tol. +0.002 -0.000	Tol. +0.000 -0.002							Tol. +0.002 -0.000	Tol. +0.000 -0.002
353	5.372	5.000	5.375	5.000	
354	5.497	5.125	5.500	5.125	
355	5.622	5.250	5.625	5.250	
356	5.747	5.375	5.750	5.375	
357	5.872	5.500	5.875	5.500	
358	5.997	5.625	6.000	5.625	
359	6.122	5.750	6.125	5.750	
360	6.247	5.875	6.250	5.875	
361	6.372	6.000	6.375	6.000	
362	6.622	6.250	6.625	6.250	
363	6.872	6.500	6.875	6.500	
364	7.122	6.750	7.125	6.750	
365	7.372	7.000	7.375	7.000	
3656	7.622	7.250	7.625	7.250	
367	7.872	7.500	7.875	7.500	
368	8.122	7.750	8.125	7.750	
369	8.372	8.000	8.375	8.000	
370	8.622	8.250	8.625	8.250	
371	8.872	8.500	8.875	8.500	
372	9.122	8.750	9.125	8.750	
373	9.372	9.000	9.375	9.000	
374	9.622	9.250	9.625	9.250	
375	9.872	9.500	9.875	9.500	
376	10.122	9.750	10.125	9.750	
377	10.372	10.000	10.375	10.000	
378	10.872	10.500	10.875	10.500	
379	11.372	11.000	11.375	11.000	
380	11.872	11.500	11.875	11.500	
381	12.372	12.000	12.375	12.000	

Radial Seal Gland Dimensions MIL-G-5514 and Industrial



1/4" CROSS SECTION

G = 0.375/0.385, G₁ = 0.475/0.485, G₂ = 0.579/0.589

Dash No.	MIL-G-5514		APS	Spring Ring II	400A	103A	RP II	Back-up Rings	Industrial	
	A Dia.	B Dia.							A Dia.	B Dia.
	Tol. +0.003 -0.000	Tol. +0.000 -0.003							Tol. +0.003 -0.000	Tol. +0.000 -0.003
409	2.977	2.500	3.000	2.500	
410	3.102	2.625	3.125	2.625	
411	3.227	2.750	3.250	2.750	
412	3.352	2.875	3.375	2.875	
413	3.477	3.000	3.500	3.000	
414	3.602	3.125	3.625	3.125	
415	3.727	3.250	3.750	3.250	
416	3.852	3.375	3.875	3.375	
417	3.977	3.500	4.000	3.500	
418	4.102	3.625	4.125	3.625	
419	4.227	3.750	4.250	3.750	
420	4.352	3.875	4.375	3.875	
421	4.477	4.000	4.500	4.000	
422	4.602	4.125	4.625	4.125	
423	4.727	4.250	4.750	4.250	
424	4.852	4.375	4.875	4.375	
425	4.974	4.497	5.000	4.500	
426	5.099	4.622	5.125	4.625	
427	5.224	4.747	5.250	4.750	
428	5.349	4.872	5.375	4.875	
429	5.474	4.997	5.500	5.000	
430	5.599	5.122	5.625	5.125	
431	5.724	5.247	5.750	5.250	
432	5.849	5.372	5.875	5.375	
433	5.974	5.497	6.000	5.500	
434	6.099	5.622	6.125	5.625	
435	6.224	5.747	6.250	5.750	
436	6.349	5.872	6.375	5.875	
437	6.474	5.997	6.500	6.000	
438	6.724	6.247	6.750	6.250	
439	6.974	6.497	7.000	6.500	
440	7.224	6.747	7.250	6.750	
441	7.474	6.997	7.500	7.000	
442	7.724	7.247	7.750	7.250	
443	7.974	7.497	8.000	7.500	
444	8.224	7.747	8.250	7.750	
445	8.474	7.997	8.500	8.000	
446	8.974	8.497	9.000	8.500	
447	9.474	8.997	9.500	9.000	
448	9.974	9.497	10.000	9.500	

G = 0.375/0.385, G₁ = 0.475/0.485, G₂ = 0.579/0.589

Dash No.	MIL-G-5514		APS	Spring Ring II	400A	103A	RP II	Back-up Rings	Industrial	
	A Dia.	B Dia.							A Dia.	B Dia.
	Tol. +0.003 -0.000	Tol. +0.000 -0.003							Tol. +0.003 -0.000	Tol. +0.000 -0.003
449	10.474	9.997	10.500	10.000	
450	10.974	10.497	11.000	10.500	
451	11.474	10.997	11.500	11.000	
452	11.974	11.497	12.000	11.500	
453	12.474	11.997	12.500	12.000	
454	12.974	12.497	13.000	12.500	
455	13.474	12.997	13.500	13.000	
456	13.974	13.497	14.000	13.500	
457	14.474	13.997	14.500	14.000	
458	14.974	14.497	15.000	14.500	
459	15.474	14.997	15.500	15.000	
460	15.974	15.497	16.000	15.500	



Inside Face Seal Gland Dimensions

1/16" CROSS SECTION

L = 0.056/0.058, G = 0.094/0.104

Dash No.	A Dia.		B Dia.		400A	103A	1100A	APS
	Tol. +0.005 -0.000	Max. (Ref.)	Tol. +0.005 -0.000	Max. (Ref.)				
008	0.312	0.125						
009	0.343	0.156						
010	0.375	0.187						
011	0.437	0.250						
012	0.500	0.312						
013	0.562	0.375						
014	0.625	0.437						
015	0.687	0.500						
016	0.750	0.562						
017	0.812	0.625						
018	0.875	0.687						
019	0.937	0.750						
020	1.000	0.812						
021	1.062	0.875						
022	1.125	0.937						
023	1.187	1.000						
024	1.250	1.062						
025	1.312	1.125						
026	1.375	1.187						
027	1.437	1.250						
028	1.500	1.312						
029	1.625	1.437						
030	1.750	1.562						
031	1.875	1.687						
032	2.000	1.812						
033	2.125	1.937						
034	2.250	2.062						
035	2.375	2.187						
036	2.500	2.312						
037	2.625	2.437						
038	2.750	2.562						
039	2.875	2.687						
040	3.000	2.812						
041	3.125	2.937						
042	3.375	3.187						
043	3.625	3.437						
044	3.875	3.687						
045	4.125	3.937						

3/32" CROSS SECTION

L = 0.089/0.091, G = 0.141/0.151

Dash No.	A Dia.		B Dia.		400A	103A	1100A	APS
	Tol. +0.005 -0.000	Max. (Ref.)	Tol. +0.005 -0.000	Max. (Ref.)				
110	0.562	0.280						
111	0.625	0.343						
112	0.687	0.405						
113	0.750	0.468						
114	0.812	0.530						
115	0.875	0.593						
116	0.937	0.655						
117	1.000	0.718						
118	1.062	0.780						
119	1.125	0.843						
120	1.187	0.905						
121	1.250	0.968						
122	1.312	1.030						
123	1.375	1.093						
124	1.437	1.155						
125	1.500	1.218						
126	1.562	1.280						
127	1.625	1.343						
128	1.687	1.405						
129	1.750	1.468						
130	1.812	1.530						
131	1.875	1.593						
132	1.937	1.655						
133	2.000	1.718						
134	2.062	1.780						
135	2.125	1.843						
136	2.187	1.905						
137	2.250	1.968						
138	2.312	2.030						
139	2.375	2.093						
140	2.437	2.155						
141	2.500	2.218						
142	2.562	2.280						
143	2.625	2.343						
144	2.687	2.405						
145	2.750	2.468						
146	2.812	2.530						
147	2.875	2.593						
148	2.937	2.655						
149	3.000	2.718						
150	3.062	2.780						
151	3.187	2.905						
152	3.437	3.155						
153	3.687	3.405						
154	3.937	3.655						
155	4.187	3.905						
156	4.437	4.155						
157	4.687	4.405						
158	4.937	4.655						
159	5.187	4.905						
160	5.437	5.155						
161	5.687	5.405						
162	5.937	5.655						
163	6.187	5.905						

1/8" CROSS SECTION

L = 0.121/0.123, G = 0.188/0.198

Dash No.	A Dia.		B Dia.		400A	103A	1100A	APS
	Tol. +0.005 -0.000	Max. (Ref.)	Tol. +0.005 -0.000	Max. (Ref.)				
210	1.000	0.625						
211	1.062	0.687						
212	1.125	0.750						
213	1.187	0.812						
214	1.250	0.875						
215	1.312	0.937						
216	1.375	1.000						
217	1.437	1.062						
218	1.500	1.125						
219	1.562	1.187						
220	1.625	1.250						
221	1.687	1.312						
222	1.750	1.375						
223	1.875	1.500						
224	2.000	1.625						
225	2.125	1.750						
226	2.250	1.875						
227	2.375	2.000						
228	2.500	2.125						
229	2.625	2.250						
230	2.750	2.375						
231	2.875	2.500						
232	3.000	2.625						
233	3.125	2.750						
234	3.250	2.875						
235	3.375	3.000						
236	3.500	3.125						
237	3.625	3.250						
238	3.750	3.375						
239	3.875	3.500						
240	4.000	3.625						
241	4.125	3.750						
242	4.250	3.875						
243	4.375	4.000						
244	4.500	4.125						
245	4.625	4.250						
246	4.750	4.375						
247	4.875	4.500						
248	5.000	4.625						
249	5.125	4.750						
250	5.250	4.875						
251	5.375	5.000						
252	5.500	5.125						
253	5.625	5.250						
254	5.750	5.375						
255	5.875	5.500						
256	6.000	5.625						
257	6.125	5.750						
258	6.250	5.875						
259	6.500	6.125						
260	6.750	6.375						
261	7.000	6.625						
262	7.250	6.875						
263	7.500	7.125						
264	7.750	7.375						

Inside Face Seal Gland Dimensions

1/8" CROSS SECTION

L = 0.121/0.123, G = 0.188/0.198

Dash No.	A Dia.		B Dia.		400A	103A	1100A	APS
	Tol. +0.005 -0.000	Max. (Ref.)	Tol. +0.005 -0.000	Max. (Ref.)				
265	8.000	7.625
266	8.250	7.875
267	8.500	8.125
268	8.750	8.375
269	9.000	8.625
270	9.250	8.875
271	9.500	9.125
272	9.750	9.375
273	10.000	9.625
274	10.250	9.875
275	10.750	10.375
276	11.250	10.875
277	11.750	11.375
278	12.250	11.875
279	12.750	12.375
280	13.250	12.875
281	13.750	13.375

3/16" CROSS SECTION

L = 0.186/0.188, G = 0.281/0.291

Dash No.	A Dia.		B Dia.		400A	103A	1100A	APS
	Tol. +0.005 -0.000	Max. (Ref.)	Tol. +0.005 -0.000	Max. (Ref.)				
347	4.625	4.062
348	4.750	4.187
349	4.875	4.312
350	5.000	4.437
351	5.125	4.562
352	5.250	4.687
353	5.375	4.812
354	5.500	4.937
355	5.625	5.062
356	5.750	5.187
357	5.875	5.312
358	6.000	5.437
359	6.125	5.562
360	6.250	5.687
361	6.500	5.937
362	6.750	6.187
363	7.000	6.437
364	7.250	6.687
365	7.500	6.937
366	7.750	7.187
367	8.000	7.437
368	8.250	7.687
369	8.500	7.937
370	8.750	8.187
371	9.000	8.437
372	9.250	8.687
373	9.500	8.937
374	9.750	9.187
375	10.000	9.437
376	10.250	9.687
377	10.500	9.937
378	10.750	10.187
379	11.000	10.437
380	11.500	10.973
381	12.000	11.437
382	12.500	11.937
383	13.000	12.437
384	13.500	12.937

3/16" CROSS SECTION

L = 0.186/0.188, G = 0.281/0.291

Dash No.	A Dia.		B Dia.		400A	103A	1100A	APS
	Tol. +0.005 -0.000	Max. (Ref.)	Tol. +0.005 -0.000	Max. (Ref.)				
322	1.500	0.937
323	1.625	1.062
324	1.750	1.187
325	1.875	1.312
326	2.000	1.437
327	2.125	1.562
328	2.250	1.687
329	2.375	1.812
330	2.500	1.937
331	2.625	2.062
332	2.750	2.187
333	2.875	2.312
334	3.000	2.437
335	3.125	2.562
336	3.250	2.687
337	3.375	2.812
338	3.500	2.937
339	3.625	3.062
340	3.750	3.187
341	3.875	3.312
342	4.000	3.437
343	4.125	3.562
344	4.250	3.687
345	4.375	3.812
346	4.500	3.937



. Indicates availability

NOTE:

1. If space permits, use the larger cross sections listed in these tables.
2. Diameters between those listed and diameters larger than those listed are available on request.
3. In-between cross sections and larger cross sections are available.
4. Metric sizes are also available.

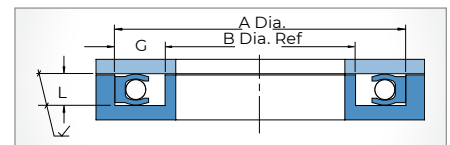

See page 19 for surface finish recommendations.



Inside Face Seal Gland Dimensions

1/4" CROSS SECTION

Dash No.	A Dia.	B Dia.	400A	103A	1100A	APS
	Tol. +0.005 -0.000	Max. (Ref.)				
409	3.000	2.250
410	3.125	2.375
411	3.250	2.500
412	3.375	2.625
413	3.500	2.750
414	3.625	2.875
415	3.750	3.000
416	3.875	3.125
417	4.000	3.250
418	4.125	3.375
419	4.250	3.500
420	4.375	3.625
421	4.500	3.750
422	4.625	3.875
423	4.750	4.000
424	4.875	4.125
425	5.000	4.250
426	5.125	4.375
427	5.250	4.500
428	5.375	4.625
429	5.500	4.750
430	5.625	4.875
431	5.750	5.000
432	5.875	5.125
433	6.000	5.250
434	6.125	5.375
435	6.250	5.500
436	6.375	5.625
437	6.500	5.750
438	6.750	6.000
439	7.000	6.250
440	7.250	6.500
441	7.500	6.750
442	7.750	7.000
443	8.000	7.250
444	8.250	7.500
445	8.500	7.750
446	9.000	8.250
447	9.500	8.750
448	10.000	9.250
449	10.500	9.750
450	11.000	10.250
451	11.500	10.750
452	12.000	11.250
453	12.500	11.750
454	13.000	12.250
455	13.500	12.750
456	14.000	13.250
457	14.500	13.750
458	15.000	14.250
459	15.500	14.750
460	16.000	15.250



L = 0.238/0.241, G = 0.375/0.385

Outside Face Seal Gland Dimensions

1/16" CROSS SECTION

Dash No.	A Dia.		B Dia.		APS	400A	400A	1100A
	Min. (Ref.)	Tol. +0.000 -0.005	Min. (Ref.)	Tol. +0.000 -0.005				
008	0.375	0.187						
009	0.406	0.218						
010	0.437	0.250						
011	0.500	0.312						
012	0.562	0.375						
013	0.625	0.437						
014	0.687	0.500						
015	0.750	0.562						
016	0.812	0.625						
017	0.875	0.687						
018	0.937	0.750						
019	1.000	0.812						
020	1.062	0.875						
021	1.125	0.937						
022	1.187	1.000						
023	1.250	1.062						
024	1.312	1.125						
025	1.375	1.187						
026	1.437	1.250						
027	1.500	1.312						
028	1.562	1.375						
029	1.687	1.500						
030	1.812	1.625						
031	1.937	1.750						
032	2.062	1.875						
033	2.187	2.000						
034	2.312	2.125						
035	2.437	2.250						
036	2.562	2.375						
037	2.687	2.500						
038	2.812	2.625						
039	2.937	2.750						
040	3.062	2.875						
041	3.187	3.000						
042	3.437	3.250						
043	3.687	3.500						
044	3.937	3.750						
045	4.187	4.000						

L = 0.056/0.058, G = 0.094/0.104

3/32" CROSS SECTION

Dash No.	A Dia.		B Dia.		400A	103A	1100A	APS
	Min. (Ref.)	Tol. +0.000 -0.005	Min. (Ref.)	Tol. +0.000 -0.005				
110	0.657	0.375						
111	0.719	0.437						
112	0.782	0.500						
113	0.844	0.562						
114	0.907	0.625						
115	0.969	0.687						
116	1.032	0.750						
117	1.094	0.812						
118	1.157	0.875						
119	1.219	0.937						
120	1.282	1.000						
121	1.344	1.062						
122	1.407	1.125						
123	1.469	1.187						
124	1.532	1.250						
125	1.594	1.312						
126	1.657	1.375						
127	1.719	1.437						
128	1.782	1.500						
129	1.844	1.562						
130	1.907	1.625						
131	1.969	1.687						
132	2.032	1.750						
133	2.094	1.812						
134	2.157	1.875						
135	2.219	1.937						
136	2.282	2.000						
137	2.344	2.062						
138	2.407	2.125						
139	2.469	2.187						
140	2.532	2.250						
141	2.594	2.312						
142	2.657	2.375						
143	2.719	2.437						
144	2.782	2.500						
145	2.844	2.562						
146	2.907	2.625						
147	2.969	2.687						
148	3.032	2.750						
149	3.094	2.812						
150	3.157	2.875						
151	3.282	3.000						
152	3.532	3.250						
153	3.782	3.500						
154	4.032	3.750						
155	4.282	4.000						
156	4.532	4.250						
157	4.782	4.500						
158	5.032	4.750						
159	5.282	5.000						
160	5.532	5.250						
161	5.782	5.500						
162	6.032	5.750						
163	6.282	6.000						

L = 0.089/0.091, G = 0.141/0.151

1/8" CROSS SECTION

Dash No.	A Dia.		B Dia.		400A	103A	1100A	APS
	Min. (Ref.)	Tol. +0.000 -0.005	Min. (Ref.)	Tol. +0.000 -0.005				
208	1.000	0.625						
209	1.063	0.687						
210	1.125	0.750						
211	1.188	0.812						
212	1.250	0.875						
213	1.313	0.937						
214	1.375	1.000						
215	1.438	1.062						
216	1.500	1.125						
217	1.563	1.187						
218	1.625	1.250						
219	1.688	1.312						
220	1.750	1.375						
221	1.813	1.437						
222	1.875	1.500						
223	2.000	1.625						
224	2.125	1.750						
225	2.250	1.875						
226	2.375	2.000						
227	2.500	2.125						
228	2.625	2.250						
229	2.750	2.375						
230	2.875	2.500						
231	3.000	2.625						
232	3.125	2.750						
233	3.325	2.875						
234	3.375	3.000						
235	3.500	3.125						
236	3.625	3.250						
237	3.750	3.375						
238	3.875	3.500						
239	4.000	3.625						
240	4.125	3.750						

L = 0.121/0.123, G = 0.188/0.198

· Indicates availability

NOTE:

1. If space permits, use the larger cross sections listed in these tables.
2. Diameters between those listed and diameters larger than those listed are available on request.
3. In-between cross sections and larger cross sections are available.
4. Metric sizes are also available.

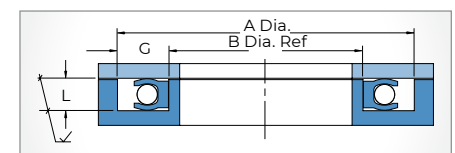

See page 19 for surface finish recommendations.

Outside Face Seal Gland Dimensions

1/8" CROSS SECTION

Dash No.	A Dia.		B Dia.		400A	103A	1100A	APS
	Min. (Ref.)	Tol. +0.000 -0.005	Min. (Ref.)	Tol. +0.000 -0.005				
241	4.250	3.875
242	4.375	4.000
243	4.500	4.125
244	4.625	4.250
245	4.750	4.375
246	4.875	4.500
247	5.000	4.625
248	5.125	4.750
249	5.250	4.875
250	5.375	5.000
251	5.500	5.125
252	5.625	5.250
253	5.750	5.375
254	5.875	5.500
255	6.000	5.625
256	6.125	5.750
257	6.250	5.875
258	6.375	6.000
259	6.625	6.250
260	6.875	6.500
261	7.125	6.750
262	7.375	7.000
263	7.625	7.250
264	7.875	7.500
265	8.125	7.750
266	8.375	8.000
267	8.625	8.250
268	8.875	8.500
269	9.125	8.750
270	9.375	9.000
271	9.625	9.250
272	9.875	9.500
273	10.125	9.750
274	10.375	10.000
275	10.875	10.500
276	11.375	11.000
277	11.875	11.500
278	12.375	12.000
279	13.375	13.000
280	14.375	14.000
281	15.375	15.000

L = 0.121/0.123, G = 0.188/0.198

3/16" CROSS SECTION

Dash No.	A Dia.		B Dia.		400A	103A	1100A	APS
	Min. (Ref.)	Tol. +0.000 -0.005	Min. (Ref.)	Tol. +0.000 -0.005				
325	2.062	1.500
326	2.187	1.625
327	2.312	1.750
328	2.437	1.875
329	2.562	2.000
330	2.687	2.125
331	2.812	2.250
332	2.937	2.375
333	3.062	2.500
334	3.187	2.625
335	3.312	2.750
336	3.437	2.875
337	3.562	3.000
338	3.687	3.125
339	3.812	3.250
340	3.937	3.375
341	4.062	3.500
342	4.187	3.625
343	4.312	3.750
344	4.437	3.875
345	4.562	4.000
346	4.687	4.125
347	4.812	4.250
348	4.937	4.375
349	5.062	4.500
350	5.187	4.625
351	5.312	4.750
352	5.437	4.875
353	5.562	5.000
354	5.687	5.125
355	5.812	5.250
356	5.937	5.375
357	6.062	5.500
358	6.187	5.625
359	6.312	5.750
360	6.437	5.875
361	6.562	6.000
362	6.687	6.125
363	6.812	6.250
364	7.062	6.500
365	7.312	6.750
366	7.562	7.000
367	7.812	7.250
368	8.062	7.500
369	8.312	7.750
370	8.562	8.000
371	8.812	8.250
372	9.062	8.500
373	9.312	8.750
374	9.562	9.000
375	9.812	9.250
376	10.062	9.500
377	10.312	9.750
378	10.562	10.000

L = 0.186/0.188, C = 0.281/0.291

Dash No.	A Dia.		B Dia.		400A	103A	1100A	APS
	Min. (Ref.)	Tol. +0.000 -0.005	Min. (Ref.)	Tol. +0.000 -0.005				
379	10.812	10.250
380	11.062	10.500
381	11.312	10.750
382	12.562	11.000
383	12.062	11.500
384	12.562	12.000

L = 0.186/0.188, G = 0.281/0.291

Outside Face Seal Gland Dimensions



1/4" CROSS SECTION

Dash No.	A Dia.	B Dia.	400A	103A	1100A	APS
	Min. (Ref.)	Tol. +0.000 -0.005				
409	3.250	2.500
410	3.375	2.625
411	3.500	2.750
412	3.625	2.875
413	3.750	3.000
414	3.875	3.125
415	4.000	3.250
416	4.125	3.375
417	4.250	3.500
418	4.375	3.625
419	4.500	3.750
420	4.625	3.875
421	4.750	4.000
422	4.875	4.125
423	5.000	4.250
424	5.125	4.375
425	5.250	4.500
426	5.375	4.625
427	5.500	4.750
428	5.625	4.875
429	5.750	5.000
430	5.875	5.125
431	6.000	5.250
432	6.125	5.375
433	6.250	5.500
434	6.375	5.625
435	6.500	5.750
436	6.625	5.875
437	6.750	6.000
438	7.000	6.250
439	7.250	6.500
440	7.500	6.750
441	7.750	7.000
442	8.000	7.250
443	8.250	7.500
444	8.500	7.750
445	8.750	8.000
446	9.250	8.500
447	9.750	9.000
448	10.250	9.500
449	10.750	10.000
450	11.250	10.500
451	11.750	11.000
452	12.250	11.500
453	12.750	12.000
454	13.250	12.500
455	13.750	13.000
456	14.250	13.500
457	14.750	14.000
458	15.250	14.500
459	15.750	15.000
460	16.250	15.500



L = 0.283/0.241, G = 0.375/0.385

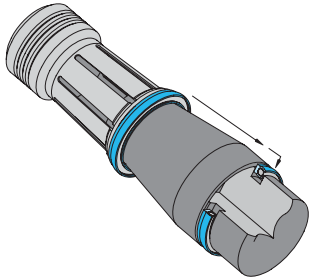

Unlike elastomeric and polyurethane seals, Omniseal® spring-energized seals resist stretching. Similarly, our seals can scratch and take a permanent set much more easily. Care should be taken while installing Omniseal® seals to avoid seal damage. The seals should be installed in open or split groove designs to avoid stretching or compressing the seal.

To avoid seal damage when installing Omniseal® seals in closed (non-split) or partially open grooves, please use special installation tools. Omniseal Solutions can design installation tools for your specific needs. The hardware surface should be free of scratches and sharp edges that can cause permanent damage to the seal.

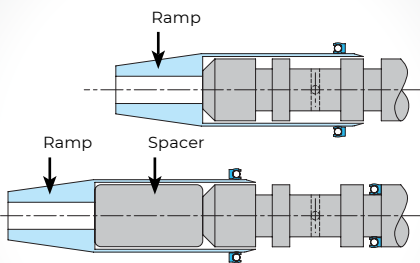

If the Omniseal® seal is installed in a piston housing, the seal must be stretched. An installation tool with a ramp and sleeve is recommended for this type of application. The seal is easily transferred to the sleeve by loading from the ramp side and moved from the sleeve onto the gland using a pusher. During the process, the seal will expand and normally will require recovery time to return to its nominal diameter. If the installation has to be done immediately, a mechanical compression tool is recommended. The ramp in the tool will compress the seal to its original diameter. The tool should be allowed to remain in place on top of the Omniseal® seal for approximately one minute to allow the seal to return to its original diameter.

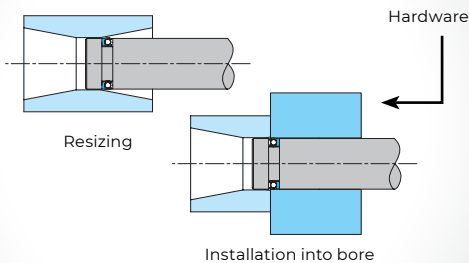

For installation in a bore housing, the Omniseal® seal must be compressed. This can be done by loading the seal inside the sleeve of the installation tool. Position the sleeve adjacent to the housing and transfer the seal onto the housing using a pusher. Use a resizing tool with a ramp to return the seal to its original dimension.

Note: To install two or more Omniseal® products into closed glands on a common shaft, install the farthest seal first. Use a simple spacer to adjust the ramp and position the next seal and gland for installation.

Larger diameter seals may not require a special installation tool if the seal can be pushed onto the housing with minimal force. When allowed, lubricants (grease, oil, etc.) compatible with the media to be sealed can ease assembly.

Resized (left); Installation into bore (right)

Omniseal® 400A, APS and 103A seals can be installed into closed glands if needed. Spring Ring II and RP II seals are not recommended for closed gland installation because of possible damage to the spring. Similarly, small diameter 400A type seals are not recommended for installation in closed grooves. Seals with larger diameters are typically easier to install in closed grooves. For seals that have a diameter to cross-section ratio smaller than 20:1, please consult our Technical Support team at help@omniseal-solutions.com or refer to the back page for site contact information.

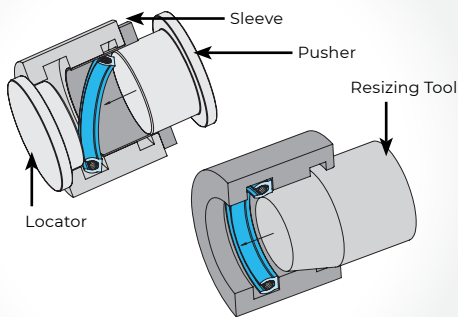

Installation of Omniseal® APS seal in closed rod gland (left); Completion of installation (right)

Warning: To avoid damage to the jacket and spring, do not use hand tools such as screwdrivers to force Omniseal® seals into closed glands. Please contact our Technical Support team when working with a closed gland design. Refer to the back cover for specific site contact information.

	<p>Anti-Blowout Rod Seals</p> <p>This unique design has been used in the valve industry for more than 50 years. In applications requiring the rod to disengage from the seal, the anti-blowout design prevents the dynamic sealing lip from deforming under pressure.</p>
	<p>Anti-Blowout Ball Valve Seals</p> <p>Ball valve seals are machined to the exact tolerances called for by manufacturers. A highly successful example of this type of seal is the anti-blowout design, which is used in petrochemical valves. Our engineers assist customers in designing a captive anti-blowout feature into hardware.</p>
	<p>Integral Piston Seals</p> <p>For small diameter applications at moderate pressures, the integral piston seal is an innovative approach to reducing the number of precision machined metal parts and components. In addition to allowing easy assembly, this design serves as a seal and as a guide bearing.</p>
	<p>Bidirectional Seals</p> <p>This versatile design combines two seals and a guide bearing into a one-piece component. The bidirectional seal is recommended for moderate temperature/pressure applications where simple assembly and quick replacement are required. When designed without an inside diameter it also serves as a floating piston.</p>
	<p>Sanitary Seals</p> <p>The JS design shields the spring from the media, prevents entrapment in the spring and allows easier cleaning. This design is excellent in food filling and other dispensing equipment.</p>
	<p>OmniGasket™ Seals</p> <p>OmniGasket™ seals are spring-energized seals retained in a metal plate designed to customer specifications. This seal saves hardware design and machining costs and offer easy change out of the seals in the field. These advantages have made OmniGasket™ seals preferred for use in gas turbine engine and aerospace hydraulic applications.</p>

	<p>Formed Seals</p> <p>Our formed seals are a unique specialty sealing product. Omniseal Solutions has the ability to manufacture most of the major seal cross sections in special shapes to fit the customer's hardware. Successful applications of formed seals include aerospace access doors and liquid heat exchangers.</p>
	<p>High-Pressure Seals with Back-up Rings</p> <p>A number of design options are available for high-pressure sealing problems. Back-up rings can be configured into most seal types to prevent extrusion of the jacket material. Pressure actuated back-up rings are often recommended for closing multiple gaps or for dealing with hardware side loads.</p>
	<p>Belleville Spring Seals</p> <p>Face seals energized with Belleville washers provide high deflection without risk of the spring collapsing. Another advantage of a Belleville seal is that they can be manufactured in smaller diameters than most spring-energized seals.</p>
	<p>LFE and HPHT Seals with V-Packings and T-Spacers</p> <p>In response to the critical need for low fugitive emissions (LFE) from valves, Omniseal Solutions developed a range of high-performance stem sealing systems that protect the environment and adhere to the most stringent standards of the oil and gas industry. Omniseal® LFE designs that comply with ISO-15848 and Shell SPE 77-312 are available. In some applications, the back pressure can reach levels high enough to damage the seal. A T-Spacer can prevent damage to the lips of the Omniseal® seal.</p>
	<p>Multiple Energizers</p> <p>If the cross section of the seal is too big compared to the other seal dimensions, a multiple spring design may be preferred.</p>

Chemical Compatibility Guide



Omiseal Solutions
SAINT-GOBAIN

Chemicals	PTFE	UHMWPE	TPE	Type 304 SS	Hastelloy® C-276	Elgiloy®
Acetaldehyde	A	C	—	A	A	A
Acetamide	A	A	—	A	—	—
Acetate Solvent	A	A	—	A	A	A
Acetic Acid	A	A ²	A	D	A	A
Acetic Acid, 20%	A	A	A	B	A	A
Acetic Acid, 80%	A	A	—	D	A	A
Acetic Acid, Glacial	A	D	—	C	A	A
Acetic Anhydride	A	D	B	B	A	A
Acetone	A	B	B	A	A	A
Acetyl Chloride (dry)	A	D	—	A	A	A
Acetylene	A	D	A	A	—	A
Acrylonitrile	A	A	—	A ¹	B	—
Adipic Acid	A	A	—	A ¹	—	—
Alcohols:						
Arnyl	A	B ²	A	A	A	A
Benzyl	A	D	—	A	A	A
Butyl	A	A	—	A	A	A
Discertone	A	B ¹	—	A	A	A
Ethyl	A	B	A	A	A	A
Hexyl	A	A	—	A	A	A
Isobutyl	A ²	A ²	—	A	A	A
Isopropyl	A ²	A ²	A	B	A	A
Methyl	A	A ¹	B	A	A	A
Octyl	—	A	—	A	C	A
Propyl	A	A ²	—	A	A	A
Aluminum Chloride	A	B ²	C	B	A	B
Aluminum Chloride, 20%	A	B ²	—	D	A	C
Aluminum Fluoride	A	A ²	—	D	B	C
Aluminum Hydroxide	A	A ²	—	A ¹	B	—
Aluminum Nitrate	A	A ²	—	A	—	—
Alum. Potassium Sulfate	A	A ²		D	C	—
Aluminum Sulfate	A	A ²	B ¹	B	B	—
Alums	A	A	D	—	B	—
Amines	A ²	C ¹	A ¹	A	B	A
Ammonia 10%	A	C ¹	—	A	A	A
Ammonia Nitrate	A	A	—	A	—	A
Ammonia, Anhydrous	A	B ²	D	A	B	A
Ammonia, Liquid	A	C ¹	—	B ²	B	B
Ammonium Acetate	A	A	—	B	—	—
Ammonium Bifluoride	A	A ²	—	D	B	C
Ammonium Carbonate	A	B ²	—	B	B	—
Ammonium Chloride	A	A ²	A ¹	C	D	A
Ammonium Hydroxide	A	A ¹	C	A ¹	B	A

Chemicals	PTFE	UHMWPE	TPE	Type 304 SS	Hastelloy® C-276	Elgiloy®
Ammonium Nitrate	A	A ¹	B ¹	A ¹	B	—
Ammonium Persulfate	A ¹	A ²	—	A	B	—
Ammonium Phosphate:						
Dibasic	A ²	A ²	—	B	B	—
Monobasic	A	A	B ¹	B	B	—
Tribasic	A	C	—	B	B	—
Ammonium Sulfate	—	A ¹	B ¹	B	B	A
Amyl Acetate	A	C ¹	C ¹	A	A	—
Amyl Alcohol	A ²	B ¹	A	A	A	A
Amyl Chloride	A	D	—	A ²	A ¹	—
Aniline	A	C	D	A	B	—
Aniline Hydrochloride	A	D	—	D	D	—
Antimony Trichloride	A	B ²	—	B	A ²	B ¹
Aqua Regia	A	B ¹	C ¹	D	C	D
Arochlor 1248	A	C ¹	C ¹	B	A	—
Aromatic Hydrocarbons	—	C	C ¹	—	—	—
Arsenic Acid	A	B ²	—	A ²	B	—
Asphalt	A ¹	A ¹	B ¹	B	—	—
Barium Carbonate	A	B ²	—	B ¹	B	—
Barium Chloride	A	A ¹	B ¹	A ¹	B	—
Barium Cyanide	A ¹	B	—	A ¹	A	—
Barium Hydroxide	A	B ²	B ¹	B	B	—
Barium Nitrate	A	B ²	A	A	A	A
Barium Sulfate	A	B ²	D	B	A	—
Barium Sulfide	A	B ²	—	B	—	—
Benzaldehyde	A ¹	A ¹	B	B	A	—
Benzene	A	C ¹	C	B	B	—
Benzene Sulfonic Acid	A	A ¹	B	B	B	—
Benzoic Acid	A ¹	A ¹	D	B	B ¹	—
Benzol	A	C ¹	C	A ¹	B	—
Boric Acid	A	A ²	A ¹	B ²	A	—
Bromine	A	D	D	D	A	C
Butadiene	D	—	A	C	—	—
Butane	A	C ¹	—	A ²	A	A
Butylacetate	A	C ¹	B	B	A	—
Butylene	A	B ¹	—	A	—	—
Butyric Acid	D	B ¹	B ²	A ¹	—	—
Calcium Bisulfide	A	B ¹	B ¹	B	A	—
Calcium Carbonate	A	B ¹	—	A ¹	B	—
Calcium Chloride	A	B ²	A ¹	C ²	A	C
Calcium Hydroxide	A	A ²	B ¹	B ¹	A	A
Calcium Hypochlorite	A	A ¹	C ¹	C ¹	B	C

Key
A: No Effect/Excellent
B: Minor Effect
C: Moderate Effect/Fair
D: Severe Effect/Not Recommended
¹Satisfactory up to 72°F (22°C)
²Satisfactory up to 120°F (48°C)

Chemicals	PTFE	UHMWPE	TPE	Type 304 SS	Hastelloy® C-276	Elgiloy®
Calcium Oxide	A	B ¹	A	A	A	A
Calcium Sulfate	A	B ¹	—	B	B	—
Carbon Bisulfide	—	—	C ¹	A	—	—
Carbon Dioxide	A	A ¹	A	A	A	A
Carbon Dioxide (Dry)	A	A ¹	A ¹	A	A	A
Carbon Dioxide (Wet)	A	A ¹	—	A	A	A
Carbon Disulfide	A	C ¹	—	A ¹	B	—
Carbon Monoxide	A	A ²	A	A	B	A
Carbon Tetrachloride	A	D	D	B	A ¹	A
Carbonic Acid	A	B ²	D	A ¹	A ²	—
Catsup	—	—	—	A	—	A
Chlorinated Glue	—	—	—	—	—	—
Chlorine Water	A	B ¹	—	C ²	A	A
Chlorine, Anhydrous Liquid	A	D	—	C ¹	D	—
Chlorine, Dry	A	D	D	A ¹	A ²	A
Chlorobenzene (Mono)	B	C ¹	D	A	A	—
Chloroform	A ¹	C ¹	D	A	A ¹	A
Chlorosulfonic Acid	A	D	D	D	A ¹	—
Chromic acid 5%	A	D	D	B	B	B
Chromic Acid 10%	A	D	D	B	A	B
Chromic Acid 30%	A	D	D	B ²	D	B
Chromic Acid 50%	A	D	D	C	B	C
Cider	—	B	B ¹	A	—	A
Citric Acid	A	D	A ¹	B ¹	A	A
Clorox (Bleach)	A	—	—	A	A	A
Coffee	—	—	—	A	A	A
Copper Chloride	A	—	A ¹	D	—	—
Copper Cyanide	A	B ²	—	B	A ¹	—
Copper Fluoborate	—	—	—	D	B	—
Copper Nitrate	A	A ²	—	A	B ²	—
Copper Sulfate 5%	A	A ²	A ¹	B	A	—
Copper Sulfate >5%	A	A ²	A ¹	B	A	—
Cream	A	—	—	A	—	A
Cresola	—	C ¹	D	A ²	B ²	—
Cresylic Acid	A	B ¹	—	A ¹	B ¹	—
Cyclohexane	A	B ¹	A ¹	A ¹	B	—
Cyclohexanone	A	D	—	A ¹	A ¹	—
Detergents	A	D	—	A ²	B	A
Diacetone Alcohol	A	A	—	B ¹	—	—
Dichloroethane	A ¹	C ¹	—	C ¹	A	—
Diesel Fuel	A	C ¹	—	A ¹	B	A
Diethyl Ether	A	—	C	B ¹	B ¹	A

Chemicals	PTFE	UHMWPE	TPE	Type 304 SS	Hastelloy® C-276	Elgiloy®
Disthylamine	D	D	—	A	A	A
Diethylene Glycol	A ²	B ²	—	A ¹	B ¹	A
Dimethyl Formamide	D	A	—	A	—	—
Diphenyl Oxide	A ¹	—	—	B ¹	B ¹	—
Epsom Salts	A	A ²	—	A	B	A
Ethane	A	—	—	A	—	A
Ethanol	A	B	—	A	A	A
Ethanolamine	A ¹	—	—	A	B	—
Ether	A	D	—	A	B ¹	A
Ethyl Acetate	A	D	B	B	A	A
Ethyl Benzoate	A	C ²	—	—	—	—
Ethyl Chloride	A	C ¹	C	A	B ¹	—
Ethylene Bromide	A	D	—	A	B	—
Ethylene Chloride	A	D	—	B	—	—
Ethylene Chlorohydrin	A	D	—	B	B	—
Ethylene Diamine	A	A ¹	—	B ¹	C	—
Ethylene Dichloride	A	D	C	B	B	—
Ethylene Glycol	A	D	A	B	B ¹	A
Ethylene Oxide	A	A	A	B	A	A
Patty Acids	A	D	—	B	A	A
Ferric Chloride	A	A ¹	C	D	B ²	C
Ferric Nitrate	A	A ²	—	B	B ¹	B
Ferric Sulfate	A	A ²	—	B ¹	A ¹	B
Ferrous Chloride	A	A ²	—	D	B ¹	C
Ferrous Sulfate	A	A ²	—	B	B	B
Fluboric Acid	A	A ²	—	B	A ¹	—
Fluorine	D	D	—	C	B ¹	C
Fluosilicic Acid	A	A ²	—	C	B	—
Formaldehyde 40%	A	D	B	A ¹	B	A
Formaldehyde 100%	A	B	—	C	A	A
Formic Acid	A	D	B	B ¹	A	A
Freon 11	A	C	A	A	A	A
Freon 12	A	A ¹	A	B ¹	A	A
Freon 22	A	—	—	A	A	A
Freon 113	A	—	A	—	A	A
Freon TF	A	—	A	A	A	A
Fruit Juice	A	A	—	A	A	A
Fuel Oils	B	B	—	A	A ¹	A
Furan Resin	A	D	—	A ¹	B	—
Furfural	A	D	—	A	B	—
Galic Acid	B	A	—	A	B ¹	—
Gasoline	B	A	A	A	A	A

Key

- A: No Effect/Excellent
- B: Minor Effect
- C: Moderate Effect/Fair
- D: Severe Effect/Not Recommended
- ¹Satisfactory up to 72°F (22°C)
- ²Satisfactory up to 120°F (48°C)

Chemical Compatibility Guide



Omniseal Solutions
SAINT-GOBAIN

Chemicals	PTFE	UHMWPE	TPE	Type 304 SS	Hastelloy® C-276	Elgiloy®
Gelatin	A	A ²	—	A ²	A	A
Glucose	A	A ²	—	A ¹	A	A
Glue, PVA	A	A ²	A	A ¹	A	A
Glycerin	A	A ¹	A	A ²	A	A
Glycolic Acid	A	A ²	—	A	A	A
Grape Juice	A	B	—	A	—	A
Grease	A	—	—	—	A	A
Heptane	A	B ¹	—	A	A	A
Hexane	A	D	A	A	A	A
Honey	A	B	—	A	A	A
Hydraulic Oil (Petro)	A	C	—	A	A	A
Hydraulic Oil (Synthetic)	A	A	—	A	A	A
Hydrazine	C	—	C	A	—	—
Hydrobromic Acid 20%	—	B ²	—	D	A	C
Hydrobromic Acid 100%	A	B ¹	—	D	C	D
Hydrochloric Acid 20%	A	A ²	B	D	A ¹	B
Hydrochloric Acid 37%	A	B ²	C	D	B	C
Hydrochloric Acid 100%	A	—	—	D	A	B
Hydrocyanic Acid	A	A ²	C	B ¹	A	—
Hydrocyanic Acid Gas 10%	A	—	—	—	—	—
Hydrofluoric Acid 20%	A	A ²	—	D	B	C
Hydrofluoric Acid 50%	A	A ¹	D	D	B	C
Hydrofluoric Acid 75%	A	C ¹	D	D	B	C
Hydrofluoric Acid 100%	A	—	D	B ¹	B	C
Hydrofluosilicic Acid 20%	A	B ²	—	C ²	B	C
Hydrofluosilicic Acid 100%	A	B ¹	—	D	B	C
Hydrogen Gas	A	A ²	A	A	A	A
Hydrogen Peroxide 10%	A	A	—	B ²	A	D
Hydrogen Peroxide 30%	A	C ²	—	B ²	A	D
Hydrogen Peroxide 50%	A	C ²	—	B ²	A	D
Hydrogen Peroxide 100%	A	C ²	—	B ²	A	D
Hydrogen Sulfide (Aqua)	A	A	—	C	A	A
Hydrogen Sulfide (Dry)	A	A	A	C ¹	A	A
Hydroquinone	A	A	—	B	B	—
Hydroxyacetic Acid 70%	A	A	—	—	—	—

Chemicals	PTFE	UHMWPE	TPE	Type 304 SS	Hastelloy® C-276	Elgiloy®
Iodine	A	A ¹	B	D	A	D
Isopropyl Acetate	A	B ²	C	C	B	—
Isopropyl Ether	A ¹	B	—	A	A	A
Jet Fuel (JP3,4,5,6,8)	A	D	—	A	A	A
Jet fuel (JP9, 10)	A	D	—	A	A	A
Kerosene	A	C ¹	C	A	B	A
Ketones	A	C ¹	—	A	A	A
Lacquer Thinners	A	A ²	D	A ¹	A	A
Lacquers	A	A ²	—	A ¹	A	A
Lactic Acid	A	A ¹	D	B ¹	B ¹	—
Lard	A	A	—	A	A	A
Latex	A	—	—	A ²	A	A
Lead Acetate	A	A ²	—	B ¹	B ¹	—
Lead Sulfamate	B	A ¹	—	C	—	—
Ligroin	A	A	—	—	—	—
Lime	A ¹	A	—	A	—	A
Lubricants	A	D	A	A ²	A	A
Magnesium Carbonate	A ¹	B	—	B ¹	B ¹	—
Magnesium Chloride	A	A ¹	C	D	A ²	—
Magnesium Hydroxide	A	A ²	C	B ¹	A	A
Magnesium Nitrate	A	A ²	—	B ¹	A	A
Magnesium Sulfate	A	A ²	—	A	B	—
Maleic Acid	A	B ²	—	A	B	—
Malic Acid	A	B ²	—	A	B	—
Mayonnaise	A	D	—	C	A	A
Melamine	A	—	—	—	—	—
Mercuric Chloride (Dilute)	A	A	B	C	C	D
Mercuric Cyanide	B	A	—	A	A	—
Mercury	A	A	B	A	A ²	A
Methane	A	—	—	A	A	A
Methanol	A	A ¹	B	A	A	A
Methyl Acetate	A	B ¹	—	A	A	A
Methyl Acrylate	—	—	—	A	—	—
Methyl Alcohol 10%	A	A ¹	B	A	A	A
Methyl Bromide	A	C ¹	—	B ¹	—	—
Methyl Cellosolve	A	—	—	A	—	—
Methyl Chloride	A	C ¹	—	—	B	B
Methyl Dichloride	—	—	—	B ¹	—	—
Methyl Ethyl Ketone (MEK)	A	B ²	B	A	A	A
Methyl Isobutyl Ketone	A	C	B	A	A	A
Methyl Isopropyl Ketone	A	D	—	B ¹	—	A
Methylamine	A	A ¹	—	A	—	—
Methylene Chloride	A	C	D	A	B	—
MIL-H-5606	A	—	—	A	—	—
MIL-L-7808	A	—	—	A	—	—
MIL-L-23699	A	—	—	A	—	—
MIL-H-46170	A	—	—	A	—	—
Milk	A	A	—	A	A	A
Mineral Spirits	A	B	—	A	B	A

Key
A: No Effect/Excellent
B: Minor Effect
C: Moderate Effect/Fair
D: Severe Effect/Not Recommended
¹Satisfactory up to 72°F (22°C)
²Satisfactory up to 120°F (48°C)

Chemicals	PTFE	UHMWPE	TPE	Type 304 SS	Hastelloy® C-276	Elgiloy®
Molasses	A	A	—	A	A	A
Monoethanolamine	A	C	—	A	—	A
Mustard	A	A	—	A	A	A
Naphtha	B	A ¹	B	A	B	A
Nephtanlene	A	C	B	A	A	A
Nickel Chloride	A	A	—	D	B	C
Nickel Sulfate	A ²	A	—	B ¹	B	—
Nitric Acid (5-10%)	A	B	C	A	A ¹	A
Nitric Acid (20%)	A	C	D	A	A ¹	A
Nitric Acid (50%)	A	B ¹	D	A ²	A ¹	A
Nitric Acid (Concentrated)	A	C ¹	D	A ¹	B ¹	A
Nitrobenzene	A	C ¹	D	B	D	—
Nitrous Acid	A	—	—	B	D	—
Nitrous Oxide	A	C	—	B	B	—
Oils:						
Aniline	A	—	D	A	B	A
Castor	A	—	B ¹	A	—	A
Cocoa Nut	A	A	—	A	A	A
Cod Liver	A	—	—	A	A	A
Corn	A	A	A	A	A	A
Cotton Seed	A	A	A ¹	A	A	A
Creosote	A	C	D	B	B	A
Diesel Fuel	A	A	A ¹	A	B	A
Fuel	A	B	A	A	A ¹	A
Ginger	A	—	—	D	—	A
Lemon	A	—	—	A	—	A
Linseed	A	A	B ¹	A	B	A
Mineral	A	B ¹	A	A	A	A
Olive	A ¹	A ¹	—	A	A	A
Orange	—	C ¹	—	A	A	A
Palm	A	A	—	A	—	A
Peanut	A	A	—	A	—	A
Peppermint	A	—	—	A	—	A
Pine	A	D	—	A	—	A
Rapeseed	A	D	—	A	—	A
Rosin	A	B ²	—	A ¹	A	A
Sesame Seed	A	—	—	A	—	A
Silicone	A	A	A	A	A	A
Soybean	A	A ¹	B	A	A	A
Tanning	—	—	—	A	—	A
Transformer	A	C ¹	—	A	—	A
Turbine	A	C	—	A	—	A

Chemicals	PTFE	UHMWPE	TPE	Type 304 SS	Hastelloy® C-276	Elgiloy®
Oleic Acid	A	C ²	A	A	A ²	A
Oleum 25%	A	D	C	B ²	A	—
Oleum 100%	A	D	—	A	D	—
Oxalic Acid (Cold)	A ¹	A ²	D	B	B	B
Ozone	A	A	C	B	—	A
Paraffin	A	B	—	A	B	A
Pentane	A	D	—	C	A	A
Pentane	A	D	—	C	A	A
Perchloric Acid	A	B	—	C	B	—
Perchloroethylene	A	D	C	B	B	—
Petroleum	C	B	—	A	A	—
Phenol (10%)	A	B	—	B	B	—
Phosphoric Acid (<40%)	A	A	—	D	A ²	C
Phosphoric Acid (>40%)	A	B ¹	—	D	A ²	C
Phosphoric Acid (Crude)	A	B ¹	—	D	A ²	—
Photographic Developer	A	A	—	A	B	—
Phthalic Anhydride	A	—	—	A	A	—
Picric Acid	A	A	—	B	B	—
Potash	—	A ¹	D	B	B	A
Potassium Bicarbonate	A	A	—	B	B	—
Potassium Bromide	A	A	—	B	B	—
Potassium Chlorate	A	A ¹	—	B ¹	B	—
Potassium Chloride	A	A ¹	B	B ¹	A	B
Potassium Chromate	A ¹	A	—	B ¹	A	—
Potassium Cyanide Sols.	A	A	B	B ¹	B	—
Potassium Dichromate	A	A	C	B	B	B
Potassium Ferrocyanide	A	A ¹	—	B	B	—
Potassium Hydroxide	A	A	D	B	B ¹	B
Potassium Nitrate	A	B	B	B	B ¹	—
Potassium Permanganate	A	A	D	B ¹	A ¹	—
Potassium Sulfate	A	A ²	B	B ¹	B ¹	—
Potassium Sulfide	A	A ²	—	B	—	—
Propane (liquefied)	A	C ¹	A	A	A	A
Propylene Glycor	A	B ²	—	B	B	B
Pyridine	A	C	—	B	B	—
Pyrogalllic Acid	A	B ¹	C	A	B	—
Rosins	A	B ¹	—	A ¹	—	A
Rum	—	—	—	A	—	A
Rust Inhibitors	—	—	—	A ²	A ¹	—
Salad Dressings	—	—	—	A	—	A
Sea Water	A	A ²	A	C	A	A
Shellac (bleached)	A	A ¹	—	A	—	A

Key
A: No Effect/Excellent
B: Minor Effect
C: Moderate Effect/Fair
D: Severe Effect/Not Recommended
¹Satisfactory up to 72°F (22°C)
²Satisfactory up to 120°F (48°C)

Chemical Compatibility Guide



Omniseal Solutions
SAINT-GOBAIN

Chemicals	PTFE	UHMWPE	TPE	Type 304 SS	Hastelloy® C-276	Elgiloy®
Silicone	A	—	A	A	—	A
Silver Bromide	A	A	—	D	A	—
Silver Nitrate	A	A	—	B	A	—
Skydrol 500B	A	—	D	A	—	—
Soap Solutions	A	D	A	A	A	A
Sodium Acetate	A	A	—	B	A	A
Sodium Aluminate	A	—	—	A	B	—
Sodium Bicarbonate	A	A ²	—	A	B ¹	—
Sodium Bisulfate	A	A ²	C	D	B ²	—
Sodium Bisulfide	A	A ²	B	B ¹	B	—
Sodium Borate	A	A ²	B	B ²	A	—
Sodium Carbonate	A	B ²	—	A	A	—
Sodium Chlorate	A	B ²	—	A	B ¹	—
Sodium Chloride	A	A ²	A	B	A	A
Sodium Chromate	A	—	—	B ¹	A	—
Sodium Cyanide	A	A ²	B	A ¹	A	A
Sodium Fluoride	A ¹	A ²	—	D	A	B
Sodium Hydroxide (20%)	A	D	B	B	B	B
Sodium Hydroxide (50%)	A	D	C	B	C	B
Sodium Hydroxide (80%)	A ¹	D	—	C	A ¹	B
Sodium Hypochlorite (100%)	A	B ²	D	D	B	C
Sodium Hypochlorite (<20%)	A	A	A	C	A	B
Sodium Hyposulfate	A	—	—	A	—	—
Sodium Metaphosphate	A	A ¹	—	A	—	—
Sodium Metasilicate	A	—	—	A	A	—
Sodium Nitrate	A	A ²	—	B ¹	B	—
Sodium Perborate	A	A ¹	—	B	B	B
Sodium Peroxide	A	A	—	A	B	A
Sodium Polyphosphate	A	A	—	B	A	—
Sodium Silicate	A	A ²	—	A	B	—
Sodium Sulfate	A	A ²	—	B	B	—
Sodium Sulfite	A	B ¹	—	B	B ¹	—
Sodium Tetraborate	A	A ²	—	B	B	—
Sodium Thiosulfate (hypo)	A	A ¹	—	A ²	—	—
Stannic Chloride	A	A ²	—	D	B	C
Stannous Chloride	A	B ²	C	C ²	B	B
Starch	A	B	—	A	—	A
Stearic Acid	A	B ¹	C	B	B	—
Stoddard Solvent	A	C ¹	—	A	A	—
Styrene	A	—	D	A	D	—
Sugar (liquids)	A	—	—	A	A	A
Sulfate (liquors)	A	A ²	—	B	B	B

Chemicals	PTFE	UHMWPE	TPE	Type 304 SS	Hastelloy® C-276	Elgiloy®
Sulfur Chloride	A	C ¹	—	D	A	A
Sulfur Dioxide	A	B ¹	C	D	C	—
Sulfur Dioxide (dry)	A	A ¹	C	D	B	B
Sulfur Hexafluoride	—	B	—	—	—	A
Sulfur Trioxide	A	—	—	A	—	—
Sulfur Trioxide (dry)	A	C ¹	—	D	B	—
Sulfuric Acid (10-75%)	A	A ¹	—	D	B ¹	D
Sulfuric Acid (75-100%)	A	B ¹	C	C	B ¹	C
Sulfuric Acid (<10%)	A	A ¹	A	D	B ¹	D
Sulfuric Acid (cold conc)	A	C	B	C	A ¹	C
Sulfuric Acid (hot conc)	A	D	—	B ¹	A	A
Sulfurous Acid	A	B ²	—	B ²	B	—
Tallow	A	C	—	A	—	A
Tannic Acid	A	B ²	A	B ¹	B ¹	—
Tanning Liquors	A	A ¹	—	A ²	B	B
Tartaric Acid	A	A ¹	C	C ²	B	—
Tetrachloroethane	A	—	—	B	A	A
Tetrachloroethylene	A	B	—	—	—	A
Tetrahydrofuran	A	C ¹	B	A	A	A
Tin Salts	A	—	—	—	C	—
Toluene (toluol)	A	C ¹	B	A	A	A
Trichloroacetic Acid	A	A	—	D	B	—
Trichloroethane	A	—	—	B	A	A
Trichloroethylene	A	D	—	B	A	A
Trichloropropane	A ¹	—	—	A	A	A
Tricresylphosphate	A	B ¹	—	B	A	—
Triethylamine	A	—	—	A	—	A
Trisodium Phosphate	A	A	A	B	A	—
Turpentine	A	D	—	A	B	A
Urea	A	A	—	B	B	B
Uric Acid	A	B	—	B	B	—
Varnish	A	A	—	A	A	A
Vegetable Juice	A	—	—	A	—	A
Vinegar	A	A	—	A	A	A
Water Acid, Mine	A	A ²	—	B	A	A
Water, Distilled	A	A ²	—	A	A	A
Water, Fresh	A ¹	A ²	A	A	A	A
Water, Salt	A	A ²	A	B	A	A
Whiskey & Wines	A	C	—	A	—	A
White Liquor (pulp mill)	A	A ²	—	A	A	A
Xylene	A	B	B	B	A	A
Zinc Chloride	A	A ¹	A	B	B	—

Key
A: No Effect/Excellent
B: Minor Effect
C: Moderate Effect/Fair
D: Severe Effect/Not Recommended
¹Satisfactory up to 72°F (22°C)
²Satisfactory up to 120°F (48°C)

Application Data Form

RADIAL SEAL GROOVES (ROD/PISTON)

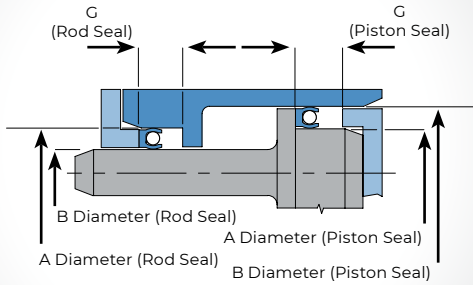

FACE SEAL GROOVE

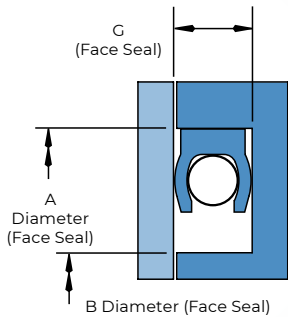

Please email
a copy of the
completed Application
Data Form to:

Omniseal Solutions

Email:
help@omniseal-solutions.com

Name _____

Title _____

Company _____

Address _____

City _____

State _____

Zip _____

Phone number _____

Fax _____

Email address _____

Date _____

Device/Application _____

Fluid/Gas to be Sealed _____

Temperature (Max./Op./Min.) _____

Pressure (Max./Op./Min.) _____

Seal Application:

Static Rotary/Oscillatory Linear/Reciprocating Motion

Rotary/Oscillatory-RPM _____

Life Requirement _____

Allowable Leakage _____

Linear/Reciprocating-Stroke Length _____

Strokes per Min _____

Seal is: Radial/Rod Radial/Piston

Face/Internal Press. Face/External Press.

A Diameter _____ Tolerance _____

B Diameter _____ Tolerance _____

Can gland be changed?: Yes No

G Dimension _ Tolerance _____

Hardware:

Dynamic Surface Static Surface

Material _____ HRC _____ HRC

Hardness _____ Ra _____ Ra

WARNING: BEFORE USE OR INCORPORATION INTO A FINISHED GOOD, EACH PRODUCT MANUFACTURED OR SOLD BY SAINT-GOBAIN PERFORMANCE PLASTICS CORPORATION (EACH HEREINAFTER REFERRED TO AS A "PRODUCT") MUST BE TESTED AND EVALUATED BY THE END-USER UNDER ACTUAL SERVICE CONDITIONS WITH SUFFICIENT SAFETY FACTORS TO DETERMINE IF SUCH PRODUCT IS SUITABLE FOR THE INTENDED USE. THE END-USER, THROUGH ITS OWN ANALYSIS AND TESTING, IS SOLELY RESPONSIBLE FOR THE SUITABILITY OF THE PRODUCT FOR ITS INTENDED USE AND FOR COMPLIANCE OF THE PRODUCT WITH ALL APPLICABLE PERFORMANCE, SAFETY AND WARNING REQUIREMENTS. THE END-USER ASSUMES ALL RISK AND LIABILITY WHATSOEVER IN CONNECTION WITH THE USE OF THE PRODUCTS IN ANY FINISHED GOOD MANUFACTURED BY END-USER.

FAILURE OF A PRODUCT CAN CAUSE EQUIPMENT FAILURE, PROPERTY DAMAGE, PERSONAL INJURY AND/OR DEATH. FINISHED GOODS INCORPORATING OR USING A PRODUCT MUST BE DESIGNED WITH SAFETY FEATURES TO PREVENT PROPERTY DAMAGE, PERSONAL INJURY AND/OR DEATH THAT CAN RESULT IN THE EVENT OF A PARTIAL OR TOTAL FAILURE OF THE PRODUCTS.

Any statements, technical information, and recommendations in this publication are believed to be reliable, but the accuracy or completeness thereof is not guaranteed. The statements, technical information and recommendations in this publication shall not be the basis of buyer's decision to purchase the Product and should not be relied upon to establish specification limits or as the basis of design. Saint-Gobain Performance Plastics Corporation makes no warranties, express or implied, and assumes no liability in connection with the use of the statements, technical information and recommendations in this publication. Saint-Gobain Performance Plastics Corporation reserves the right to make any changes without notice to the Products and to the information and contents of this or any other publication, including, without limitation, materials, dimensional attributes, performance characteristics and other properties.

Nothing contained herein or in any of our literature shall be considered a license or recommendation to use any process or to manufacture or to use any product in a manner which otherwise infringes any patent or other intellectual product right of Saint-Gobain Performance Plastics Corporation or of any third party.

Saint-Gobain Performance Plastics Corporation warrants that its products do not infringe on any patent, copyright, trade secret or other proprietary right of a third party except to the extent Customer provides the specific design of the products or any part thereof.

IF ANY PRODUCT IS RESOLD BY BUYER, A COPY OF THIS NOTICE MUST BE PROVIDED TO THE SUBSEQUENT PURCHASER/END-USER.



- 1. Acceptance Of Orders/Terms:** All orders are subject to acceptance by Saint-Gobain Performance Plastics Corporation ("SGPPL") at its Wayne, New Jersey, headquarters. SGPPL reserves the right to reject any order. Possession of a price list does not constitute an offer to sell. Acceptance of any order by SGPPL is expressly conditioned on Customer's assent to the terms and conditions set forth herein ("Terms") and the waiver by Customer of any terms and conditions contained in any order form, confirmation, or any other communication of Customer, whether previously or hereafter delivered to SGPPL, which either add to, differ from, modify, conflict with or are otherwise inconsistent with any term or condition herein. SGPPL hereby gives notice of its objection to any additional or different terms or conditions in any such order form, confirmation or communication. Customer's failure to object in writing to these Terms prior to the earlier of Customer's acceptance of the products ordered or fifteen (15) days after delivery thereof to Customer will constitute agreement by Customer to these Terms.
- 2. Product Changes:** SGPPL reserves the right to discontinue the manufacture or sale of any product at any time or to alter, modify or redesign its products.
- 3. Price:** All prices are subject to change without notice. Should any governmental action or request prevent SGPPL from implementing any price or continuing any price already in effect, SGPPL may at its option cancel Customer's order or any part thereof.
- 4. Taxes/Duties:** All federal, state or local sales, use or other taxes, and all duties, import fees or other assessments imposed on materials sold hereunder, or on the manufacture, sale or delivery thereof, shall be for Customer's account.
- 5. Credit Approval:** Customer credit approval is required prior to any shipment. If SGPPL determines at any time that Customer's financial condition does not justify the extension of credit to Customer, then SGPPL may at its option require cash payments in advance or other satisfactory security prior to delivery.
- 6. Cancellation/Change Orders:** Orders for standard products may only be revised or cancelled by Customer prior to the date of loading at the place of shipment, and only with SGPPL's prior consent. Orders for nonstandard or custom products may only be revised or cancelled by Customer prior to the commencement of production, and only with SGPPL's prior consent. Any product which SGPPL has the capability of producing but does not inventory, or does not have the capability of producing, is considered a nonstandard or custom product.
- 7. Packaging/Shipping/Risk of Loss:** Unless otherwise agreed to by SGPPL in writing (i) SGPPL shall select the method of shipment, (ii) SGPPL shall ship materials FOB (SGPPL's point of shipment), and (iii) costs for special packaging and/or handling requested by Customer shall be the responsibility of Customer. In the event of any general freight increase or any governmental ruling or regulation that results in increased freight costs, such additional costs shall be for Customer's account. Title to, and the risk of loss, damage or shortage of, such materials shall pass to Customer upon delivery to the carrier regardless of notice to Customer. SGPPL assumes no responsibility for insuring shipments unless specifically agreed to in writing by SGPPL, in which case the cost of insurance shall be for Customer's account.
- 8. Delivery:** Quoted shipping and/or delivery dates are based on estimates at the time of quotation. SGPPL shall use reasonable commercial efforts to meet such shipping and/or delivery dates, but SGPPL shall not be liable for any direct or indirect costs or damages, including without limitation incidental or consequential damages, resulting from late deliveries. For orders with indefinite delivery dates, SGPPL shall have the right to manufacture or procure the materials covered thereby and hold such materials for Customer's account pending receipt of definite shipping instructions. Except as expressly provided otherwise herein, Customer agrees to purchase and pay for all material ordered.
- 9. Claims for Loss, Damage or Shortage:** Upon delivery, shipments must be inspected by Customer for damage, loss or shortage prior to acceptance from the carrier. If damage, loss or shortage exists with respect to any shipment and it is not concealed, Customer shall secure a notation of such damage, loss or shortage from the carrier on the freight bill or delivery receipt. If damage, loss or shortage is concealed, Customer must notify the carrier within 15 days, hold the merchandise for its inspection and secure a signed report from the carrier acknowledging the damage, loss or shortage. No claims for damage, loss or shortage will be allowed unless they are accompanied by an inspection report or signed delivery receipt noting such damage, loss or shortage signed by a representative of the carrier and forwarded to SGPPL within 30 days of the invoice date. Any claims for damage, loss or shortage should also be filed by Customer with the carrier in writing immediately upon receipt of the materials. In no event shall SGPPL be liable for damage or loss to a shipment caused by a carrier.
- 10. Payment:** All invoices, whether partial or in full, shall be due and payable in full by Customer net 30 days from the date of shipment unless otherwise agreed to in writing by SGPPL. All past due, unpaid balances will bear a service charge of the lesser of one and one-half percent (1 1/2%) per month or the maximum interest rate permitted by applicable law. If Customer (i) becomes insolvent, files or has filed against it a petition in bankruptcy, makes any assignment for the benefit of creditors, or has a receiver or trustee appointed for it or its property, (ii) takes action to liquidate or otherwise cease doing business as a going concern, (iii) undergoes a change in ownership, (iv) fails to provide adequate assurance or security for credit extended, or (v) takes any other action that SGPPL determines in its sole discretion adversely impacts the conditions under which credit was extended, then all amounts outstanding from Customer hereunder shall at SGPPL's option become immediately due and payable. ALL PAYMENTS, WHETHER UNDER THE STANDARD PAYMENT TERMS OR OTHERWISE, SHALL BE CONSIDERED RECEIVED BY SGPPL AS FOLLOWS: (A) FOR PAYMENTS BY CHECK, WHEN THE CHECK IS RECEIVED AT SGPPL'S DESIGNATED PAYMENT LOCATION, AND (B) FOR PAYMENTS BY ELECTRONIC FUNDS TRANSFER, THE BUSINESS DAY IMMEDIATELY PRECEDING THE DAY ON WHICH THE FUNDS ARE IMMEDIATELY AVAILABLE TO SGPPL. Customer shall pay all undisputed invoices regardless of any dispute that may exist as to other delivered or undelivered goods. With respect to any disputed invoice, Customer shall pay all amounts not in dispute. Customer expressly waives the right to assert any offset or counterclaim with respect to amounts due under any invoice issued by SGPPL hereunder.



11. Returned Materials: Material may only be returned with the prior approval of SGPPL. Material returned without such approval will not be accepted and such approval may be conditioned upon Customer paying a restocking charge of up to 25% and freight costs of returned material (and out-freight if applicable). All returned materials must arrive at the point of return designated by SGPPL in salable condition, as determined by SGPPL's Quality Control Department, before any credit will be issued.
12. Warranty/Limitation of Liability: EXCEPT FOR PRODUCTS FOR WHICH SGPPL HAS ESTABLISHED A SPECIFIC WRITTEN WARRANTY, THE GOODS DELIVERED HEREUNDER ARE SOLD BY SGPPL WITHOUT ANY GUARANTY AND/OR WARRANTY, ORAL OR WRITTEN (WHETHER OR NOT SUCH GOODS REMAIN IN THE FORM IN WHICH THEY ARE ORIGINALLY DELIVERED TO CUSTOMER OR ARE FABRICATED BY CUSTOMER OR ANY OTHER PARTY TO PRODUCE A FINISHED PRODUCT). THE PRODUCT-SPECIFIC WRITTEN WARRANTIES REFERENCED ABOVE AND HEREBY INCORPORATED HEREIN ARE IN LIEU OF ALL OTHER WARRANTIES, EXPRESSED OR IMPLIED, ORAL OR WRITTEN, INCLUDING THE IMPLIED WARRANTIES OF MERCHANTABILITY AND FITNESS FOR A PARTICULAR PURPOSE. IN NO EVENT SHALL SGPPL BE RESPONSIBLE FOR CONSEQUENTIAL, INCIDENTAL, INDIRECT OR SPECIAL DAMAGES OF ANY KIND, INCLUDING, WITHOUT LIMITATION, ANY EXPENSE FOR REMOVAL OR REINSTALLATION RESULTING FROM ANY DEFECT, INCLUDING ANY DIMENSIONAL DEFECT INVOLVING NONSTANDARD PRODUCTS. SOME JURISDICTIONS DO NOT ALLOW THE EXCLUSION OR LIMITATION OF INCIDENTAL OR CONSEQUENTIAL DAMAGES, OR OF ANY EXPRESS OR IMPLIED WARRANTIES, SO THE ABOVE EXCLUSION MAY NOT APPLY TO CUSTOMER. THE WARRANTY PROVIDED BY SGPPL GIVES CUSTOMER SPECIFIC LEGAL RIGHTS, AND CUSTOMER MAY ALSO HAVE OTHER RIGHTS WHICH VARY FROM JURISDICTION TO JURISDICTION. NO FIELD REPRESENTATIVE, DISTRIBUTOR OR DEALER OF SGPPL IS AUTHORIZED TO MAKE ANY CHANGE OR MODIFICATION TO THESE WARRANTIES.
13. Remedies For Non-Warranty Claims: THE SOLE AND EXCLUSIVE REMEDY OF CUSTOMER AND THE SOLE AND EXCLUSIVE OBLIGATION OF SGPPL IN CONNECTION WITH CLAIMS RELATING TO MANUFACTURING DEFECTS ARE SET FORTH IN SECTION 12. THE SOLE AND EXCLUSIVE REMEDY OF CUSTOMER AND THE SOLE AND EXCLUSIVE OBLIGATION OF SGPPL FOR ANY BREACH OF CONTRACT CLAIM THAT MATERIALS DELIVERED DO NOT OTHERWISE CONFORM TO THE ACCEPTED ORDER SHALL BE EITHER THE RETURN OF CONSIDERATION PAID BY CUSTOMER TO SGPPL RELATED TO THE BREACH, OR UPON SGPPL'S ELECTION, THE DELIVERY OF CONFORMING PRODUCTS TO CUSTOMER. WITH RESPECT TO SGPPL'S NONCOMPLIANCE WITH ANY OTHER OBLIGATION OF SGPPL HEREUNDER, THE SOLE AND EXCLUSIVE REMEDY OF CUSTOMER AND THE SOLE AND EXCLUSIVE OBLIGATION OF SGPPL WILL BE AS SGPPL IN ITS DISCRETION WILL DETERMINE AS FOLLOWS: (1) SGPPL MAY ELECT TO CURE SUCH NONCOMPLIANCE WITHIN A REASONABLE PERIOD OF TIME, OR (2) IF SGPPL FAILS TO CURE SUCH NONCOMPLIANCE, CUSTOMER MAY RECOVER AN EQUITABLE AMOUNT NOT TO EXCEED SUCH CHARGES AS WERE PREVIOUSLY PAID TO SGPPL BY CUSTOMER HEREUNDER. CUSTOMER WAIVES ALL OTHER REMEDIES, STATUTORY OR OTHERWISE, INCLUDING, WITHOUT LIMITATION, THE REMEDIES OF SPECIFIC PERFORMANCE AND REPLEVIN. ANY ACTION BROUGHT BY CUSTOMER IN CONNECTION WITH SGPPL'S PERFORMANCE HEREUNDER MUST BE COMMENCED WITHIN SIX (6) MONTHS AFTER SUCH CAUSE OF ACTION ACCRUES OR IT WILL BE DEEMED WAIVED. SGPPL'S LIABILITY TO CUSTOMER, REGARDLESS OF WHETHER SUCH LIABILITY ARISES IN CONTRACT, TORT (INCLUDING, WITHOUT LIMITATION, NEGLIGENCE OR STRICT LIABILITY) OR OTHERWISE, SHALL IN NO EVENT EXCEED AMOUNTS PAID BY CUSTOMER TO SGPPL FOR THE PRODUCTS INVOLVED, AND CUSTOMER RELEASES SGPPL FROM ALL CLAIMS AND LIABILITIES IN EXCESS OF THIS LIMITATION. IN NO EVENT SHALL SGPPL BE RESPONSIBLE FOR CONSEQUENTIAL, INCIDENTAL, INDIRECT OR SPECIAL DAMAGES OF ANY KIND.
14. Excused Performance: SGPPL shall not be liable for nor be deemed to be in default of these Terms on account of any failure to perform its obligations or attempt to cure any breach thereof if SGPPL has been delayed or prevented from doing so by any cause or condition beyond SGPPL's reasonable control. If SGPPL determines that its ability to supply the total demand for the products, or obtain any or a sufficient quantity of any material used directly or indirectly in the manufacture of the products, is hindered, limited or made impracticable, SGPPL may allocate its available supply of the products or such material (without obligation to require other supplies of any such products or material) among itself and its customers as SGPPL determines in its sole discretion without liability for any failure of performance which may result therefrom. Delivery suspended or not made by reason of this action shall be cancelled without liability, but these Terms shall otherwise remain unaffected.
15. Fair Labor Standards Act: SGPPL hereby certifies that the materials sold hereunder that were produced in the United States were produced in compliance with all applicable requirements of Sections 6, 7 and 12 of the Fair Labor Standards Act, as amended, and of regulations and orders of the United States Department of Labor issued under Section 14 thereof.
16. Change In Terms and Conditions of Sale: The terms and conditions contained herein constitute the entire agreement between SGPPL and Customer and supersede any and all prior representations, agreements or understandings, whether oral or written, relative to the materials delivered hereunder. No course of dealing or usage of trade shall be relevant to supplement or explain any of these terms or conditions. No modification of these terms and conditions shall be effective unless made in writing and executed by SGPPL.
17. General: This agreement shall not be assigned by Customer without the prior written consent of SGPPL, and any assignment made without such consent shall be null and void. This agreement shall inure to the benefit of and be binding upon the parties hereto and their respective successors and permitted assigns. This agreement shall be governed by and construed in accordance with the laws of the State of New Jersey, without giving effect to its conflicts of law provisions. The courts located in New Jersey shall have exclusive jurisdiction of all matters relating to or arising out of any sale of materials by SGPPL to Customer hereunder, and Customer hereby consents to the jurisdiction of such courts.

A Global Network of Expertise and Service



● Manufacturing and sales locations ● Sales only locations ● R&D Centers

Manufacturing and sales locations

 7301 Orangewood Ave.
Garden Grove, CA USA 92841
Phone: +1-800-544-0080

 Heiveldekens 22
2550 Kontich, Belgium
Phone: +32 3-458-2828

 386 Metacom Avenue
Bristol, RI USA 02809
Phone: +1-401-253-2000

 295 Indian River Rd.
Orange, CT USA 06477
Phone: +1 203-789-8819

 17960 Englewood Dr.
Cleveland, OH USA 44130
Phone: +1 440-234-2002

 Industria Aeroespacial 3601
Parque Industrial Saltillo-Ramos
Ramos Arizpe, Coahuila, Mexico 25900
Phone: +52-844-866-1200

 Am Nordkanal 37
47877 Willich, Germany
Phone: +49 2154-600

 Av. Independencia, 7031-Jd. Sao Matheus
Sao Paulo, Vinhedo, Brazil 13280
Phone: +55 19-2127-8521

 ul. Norton 1
62-600 Kolo, Poland
Phone: +48 63-26-17-281

 10801-5, Haramura
Suwa, Japan 391-0106
Phone: +81 266-79-6400

 11th Floor., Mitta Tower
427 Teheran-ro, Gangnam-gu
Seoul, 06159, South Korea
Phone: +82-2-508-8200

 1468 Kun Yang Road
Minhang Development Zone
Shanghai, China
Phone: +86 21-5472-1568

 Grindwell Norton Limited
Devanahalli Road, Via Old Madras Road
Bangalore, India 560049
Phone: +91 80 30978888

Sales only locations

 Via Torri Bianche 9, Palazzo Quercia
Vimercate, Italy 20871
Phone: +39 039 657 8900

 Fuchu South Building 6F,
1-40 Miyamachi
Fuchu-City, Tokyo, Japan 183-0023
Phone: +81 42 352 2100

 Saint-Gobain Advanced
Materials Co., Ltd
3F-1, No. 147, Section 2, Jianguo North Road
Taipei, Taiwan 104
Phone: +886-2-2503-4201

help@omniseal-solutions.com

omniseal-solutions.com

Omniseal®, Rulon®, and Meldin® are registered trademarks of Saint-Gobain Performance Plastics Corporation.

Limited Warranty: For a period of 6 months from the date of first sale, Saint-Gobain Performance Plastics Corporation warrants this product(s) to be free from defects in manufacturing. Our only obligation will be to provide replacement product for any portion proving defective, or at our option, to refund the purchase price thereof. User assumes all other risks, if any, including the risk of injury, loss or damage, whether direct or consequential, arising out of the use, misuse, or inability to use this product(s). SAINT-GOBAIN PERFORMANCE PLASTICS DISCLAIMS ANY AND ALL OTHER WARRANTIES, EXPRESSED OR IMPLIED, INCLUDING THE IMPLIED WARRANTIES OF MERCHANTABILITY AND FITNESS FOR A PARTICULAR PURPOSE.



NOTE: Saint-Gobain Performance Plastics Corporation does not assume any responsibility or liability for any advice furnished by it, or for the performance or results of any installation or use of the product(s) or of any final product into which the product(s) may be incorporated by the purchaser and/or user. The purchaser and/or user should perform its own tests to determine the suitability and fitness of the product(s) for the particular purpose desired in any given situation.